



Pointer thermometer MESSKO® COMPACT

Operating instructions

5831400/02 EN



© All rights reserved by Maschinenfabrik Reinhausen

Dissemination and reproduction of this document and use and disclosure of its content are strictly prohibited unless expressly permitted.

Infringements will result in liability for compensation. All rights reserved in the event of the granting of patents, utility models or designs.

The product may have been altered since this document was published.

We reserve the right to change the technical data, design and scope of supply.

Generally the information provided and agreements made when processing the individual quotations and orders are binding.

The original operating instructions were written in German.

Table of contents

1	Introduction.....	7
1.1	Manufacturer.....	7
1.2	Completeness.....	7
1.3	Safekeeping.....	7
1.4	Notation conventions	7
1.4.1	Hazard communication system	7
1.4.2	Information system.....	8
1.4.3	Instruction system	9
1.4.4	Typographic conventions	9
2	Security	11
2.1	Appropriate use	11
2.2	Fundamental Safety Instructions	12
2.3	Personnel qualification.....	14
2.4	Personal protective equipment	15
3	IT security.....	16
4	Product description.....	17
4.1	Scope of delivery	17
4.2	Function description.....	17
4.3	Design.....	19
4.3.1	Compact Standard overview	19
4.3.2	Overview Compact RM	20
4.3.3	Cable glands/adapters	21
4.3.4	Ventilation	22
4.3.5	Overview Compact temperature sensor.....	22
4.4	Device versions	23
4.5	Safety markings	26
4.6	Nameplate	27

Table of contents

5	Packaging, transport and storage	28
5.1	Purpose	28
5.2	Suitability, structure and production.....	28
5.3	Markings	28
5.4	Transportation, receipt and handling of shipments.....	28
5.5	Storage of shipments.....	30
5.6	Further transport	30
6	Installation and commissioning.....	31
6.1	Transporting in the installed state.....	32
6.2	Checking measured temperature values.....	32
6.3	Mounting the pointer thermometer.....	33
6.3.1	Attaching the pointer thermometer to the transformer	33
6.3.2	Securing the capillary line	37
6.3.3	Inserting the temperature sensor	37
6.3.4	Inserting the No. 7 RM temperature sensor	40
6.3.5	Attaching the step protection (optional).....	41
6.4	Electrical connection.....	42
6.4.1	Preparation.....	43
6.4.2	Removing the bayonet seal ring.....	46
6.4.3	Opening the cover plate	47
6.4.4	Cable glands and adapters	49
6.4.5	Connecting the protective conductor.....	59
6.4.6	Connecting the interfaces (optional)	62
6.4.7	Connecting the micro-switches	67
6.4.8	Connecting cable glands/NPT adapters.....	74
6.5	Checking micro-switches	75
6.5.1	Micro-switch to the right of the pointer	75
6.5.2	Micro-switch to the left of the pointer	76

Table of contents

6.6	Setting temperature gradients (winding temperature)	78
6.6.1	Gradient setting by heating current (W)	79
6.6.2	Gradient setting by resistance value (WR).....	83
6.7	Connecting the current transformer (winding temperature).....	87
6.8	Configuring Modbus (type TTM).....	89
6.9	Closing the cover plate	90
6.10	Positioning the bayonet seal ring.....	91
7	Operation.....	92
7.1	Resetting drag hands.....	92
8	Maintenance, inspection and care	93
9	Fault elimination	94
9.1	General malfunctions (type TT)	95
9.2	General malfunctions (type TTM)	96
9.3	4...20 mA analog signal malfunctions (type TT and type TTM).....	96
9.4	Modbus communication malfunctions (type TTM).....	97
9.5	Self-diagnostic / data point DEVICE STATUS (type TTM)	98
10	Disposal.....	100
10.1	SVHC information in accordance with the REACH regulation.....	100
11	Technical data.....	101
11.1	Ambient conditions	101
11.2	Technical data	101
11.3	Micro-switches	103
11.4	Modbus RTU.....	106
12	Appendix	109
12.1	Compact pointer thermometer dimensions.....	109
12.2	Compact RM pointer thermometer dimensions	110

Table of contents

12.3	Temperature sensor	111
12.4	Step protection.....	112
12.5	Vibration-damping plate/Mounting plate	113
12.6	Cable gland dimensions	114
	Glossary	118

This technical file contains detailed descriptions on the safe and proper installation, connection, commissioning and monitoring of the product.

This technical document is intended solely for specially trained and authorized personnel.

1.1 Manufacturer

Maschinenfabrik Reinhausen GmbH
Falkensteinstrasse 8
93059 Regensburg
Germany

Tel.: +49 941 4090-0

E-mail: sales@reinhausen.com

Internet: www.reinhausen.com

MR Reinhausen customer portal: <https://portal.reinhausen.com>

Further information on the product and copies of this technical file are available from this address if required.

1.2 Completeness

This technical file is incomplete without the supporting documents:

- Order confirmation

1.3 Safekeeping

Keep this technical file and all supporting documents ready at hand and accessible for future use at all times.

1.4 Notation conventions

This section contains an overview of the symbols and textual emphasis used.

1.4.1 Hazard communication system

Warnings in this technical file are displayed as follows.

1 Introduction

1.4.1.1 Warning relating to section

Warnings relating to sections refer to entire chapters or sections, sub-sections or several paragraphs within this technical document. Warnings relating to sections have the following format:

WARNING



Type of danger!

Source of the danger and its consequences.

- ▶ Action
- ▶ Action

1.4.1.2 Embedded warning information

Embedded warnings refer to a particular part within a section. These warnings apply to smaller units of information than the warnings relating to sections. Embedded warnings use the following format:

 **DANGER!** Instruction for avoiding a dangerous situation.

1.4.1.3 Signal words

Depending on the product, the following signal words are used:

Signal word	Meaning
DANGER	Indicates a hazardous situation which, if not avoided, will result in death or serious injury.
WARNING	Indicates a hazardous situation which, if not avoided, could result in death or serious injury.
CAUTION	Indicates a hazardous situation which, if not avoided, could result in minor or moderate injury.
NOTICE	Indicates measures to be taken to prevent damage to property.

Table 1: Signal words in warning notices

1.4.2 Information system

Information is designed to simplify and improve understanding of particular procedures. In this technical file it is laid out as follows:



Important information.

1.4.3 Instruction system

This technical file contains single-step and multi-step instructions.

Single-step instructions

Instructions which consist of only a single process step are structured as follows:

Aim of action

✓ Requirements (optional).

▶ Step 1 of 1.

⇒ Result of step (optional).

⇒ Result of action (optional).

Multi-step instructions

Instructions which consist of several process steps are structured as follows:

Aim of action

✓ Requirements (optional).

1. Step 1.

⇒ Result of step (optional).

2. Step 2.

⇒ Result of step (optional).

⇒ Result of action (optional).

1.4.4 Typographic conventions

Typographic convention	Purpose	Example
UPPERCASE	Operating controls, switches	ON/OFF
[Brackets]	PC keyboard	[Ctrl] + [Alt]
Bold	Software operating controls	Press Continue button

1 Introduction

Typographic convention	Purpose	Example
...>...>...	Menu paths	Parameter > Control parameter
<i>Italics</i>	System messages, error messages, signals	<i>Function monitoring</i> alarm triggered
[▶ Number of pages]	Cross reference	[▶ Page 41].
<u>Dotted underscore</u>	Glossary entry, abbreviations, definitions, etc.	<u>Glossary entry</u> .

Table 2: Typographic conventions used in this technical file

Read this technical file through carefully to familiarize yourself with the product. This technical file is a part of the product.

- Read and observe the safety instructions provided in this chapter in particular.
- Observe the warnings in this technical file to avoid function-related dangers.

The product is manufactured based on state-of-the-art technology. Nevertheless, danger to life and limb for the user or impairment of the product and other material assets may arise in the event of improper use.

2.1 Appropriate use

The pointer thermometer measures the temperature in transformers, shunt reactors and similar equipment.

The product is designed solely for use in stationary large-scale systems.

If used as intended and in compliance with the requirements and conditions specified in this technical file as well as the warning notices in this technical file and attached to the product, then the product does not present any danger to people, property or the environment. This applies throughout the service life of the product, from delivery, installation and operation to removal and disposal.

The following is considered intended use:

- Only use the product with the transformer specified in the order.
- Operate the product in accordance with this technical documentation, the agreed-upon delivery conditions and the technical data.
- Ensure that all necessary work is performed by qualified personnel only.
- Use the equipment and special tools supplied solely for the intended purpose and in accordance with the specifications of this technical file.
- Operate the product in electrical energy systems and facilities.
- Only operate the product in industrial areas.
- Observe the notices in this technical document regarding electromagnetic compatibility and the technical data.

2 Security

2.2 Fundamental Safety Instructions

To prevent accidents, disruptions and damage as well as unacceptable adverse effects on the environment, those responsible for transport, installation, operation, maintenance and disposal of the product or parts of the product must ensure the following:

Personal protective equipment

Loosely worn or unsuitable clothing increases the danger of becoming trapped or caught up in rotating parts and the danger of getting caught on protruding parts. This results in danger to life and limb.

- All necessary devices and personal protective equipment required for the specific task, such as a hard hat, safety footwear, etc. must be worn. Observe the "Personal protective equipment" [► Section 2.4, Page 15] section.
- Never wear damaged personal protective equipment.
- Never wear rings, necklaces or other jewelry.
- If you have long hair, wear a hairnet.

Work area

Untidy and poorly lit work areas can lead to accidents.

- Keep the work area clean and tidy.
- Make sure that the work area is well lit.
- Observe the applicable laws for accident prevention in the relevant country.

Contamination level

Moisture, dust, sweat and other conductive dirt may cause malfunctions in the device. To ensure contamination level II, observe the following information:

- Wear assembly gloves.
- Ensure that no dirt or moisture enters the device when it is open.
- Close up the device after installation.

Explosion protection

Highly flammable or explosive gases, vapors and dusts can cause serious explosions and fire.

- Do not install or operate the product in areas where a risk of explosion is present.

Safety markings

Warning signs and safety information plates are safety markings on the product. They are an important aspect of the safety concept. Safety markings are depicted and described in the chapter "Product description".

- Observe all safety markings on the product.
- Make sure all safety markings on the product remain intact and legible.
- Replace safety markings that are damaged or missing.

Ambient conditions

To ensure reliable and safe operation, the product must only be operated under the ambient conditions specified in the technical data.

- Observe the specified operating conditions and requirements for the installation location.

Modifications and conversions

Unauthorized or inappropriate changes to the product may lead to personal injury, material damage and operational faults.

- Only modify the product after consultation with Maschinenfabrik Reinhausen GmbH.

Spare parts

Spare parts not approved by Maschinenfabrik Reinhausen GmbH may lead to physical injury, damage to the product and malfunctions.

- Only use spare parts that have been approved by Maschinenfabrik Reinhausen GmbH.
- Contact Maschinenfabrik Reinhausen GmbH.

2 Security

Working during operation

You must only operate the product when it is in a sound operational condition. Otherwise it poses a danger to life and limb.

- Regularly check the operational reliability of safety equipment.
- Perform the inspection tasks described in this technical document regularly.

2.3 Personnel qualification

The person responsible for assembly, commissioning, operation and inspection must have the following qualifications.

Electrically skilled person

The electrically skilled person has a technical qualification and therefore has the required knowledge and experience, and is also conversant with the applicable standards and regulations. The electrically skilled person is also proficient in the following:

- Can identify potential dangers independently and is able to avoid them.
- Is able to perform work on electrical systems.
- Is specially trained for the working environment in which (s)he works.
- Must satisfy the requirements of the applicable statutory regulations for accident prevention.

Technical Service

We strongly recommend having repairs and retrofitting carried out by our Technical Service department. This ensures that all work is performed correctly. If repair work is not carried out by our Technical Service department, please ensure that the personnel who carry out the repairs are trained and authorized to do so by Maschinenfabrik Reinhausen GmbH.

Maschinenfabrik Reinhausen GmbH

Technical Service
P.O. Box 12 03 60
93025 Regensburg
Germany

Phone: +49 941 4090-0

E-mail: service@reinhausen.com
Internet: www.reinhausen.com

2.4 Personal protective equipment

Personal protective equipment must be worn during work to minimize risks to health.

- Always wear the personal protective equipment required for the job at hand.
- Never wear damaged personal protective equipment.
- Observe information about personal protective equipment provided in the work area.

Protective clothing	Close-fitting work clothing with a low tearing strength, with tight sleeves and with no protruding parts. It mainly serves to protect the wearer against being caught by moving machine parts.
Safety shoes	To protect against falling heavy objects and slipping on slippery surfaces.
Safety glasses	To protect the eyes from flying parts and splashing liquids.
Visor	To protect the face from flying parts and splashing liquids or other dangerous substances.
Hard hat	To protect against falling and flying parts and materials.
Hearing protection	To protect against hearing damage.
Protective gloves	To protect against mechanical, thermal and electrical hazards.

Table 3: Personal protective equipment

3 IT security

Observe the following recommendations to operate the product safely:

- Ensure that only authorized personnel have access to the device.
- Ensure that the device is only operated by trained personnel who are familiar with IT security.
- If a network-based system (e.g. Ethernet) has access to the bus master, observe the IT security rules of the system used.

4.1 Scope of delivery

The product is packaged with protection against moisture and is delivered as follows:

- Pointer thermometer with temperature sensor
- Technical documents

Optional:

- Passive 4...20 mA analog output
- Active 4...20 mA analog output and Modbus RTU interface
- Standard cable gland M25x1.5 (brass), WADI cable gland (brass or stainless steel) or offshore cable gland (stainless steel) or EMC double cable gland
- 1/2" 14NPT adapters
- 3/4" 14NPT adapters
- ANSI or M plug connector
- Step protection (only in combination with sensor No. 6 VA and sensor No. 7)

Please note the following:

- Check the shipment against the shipping documents for completeness
- Store the parts in a dry place until installation
- The product must remain in the packaging and may only be removed immediately before installation

4.2 Function description

Depending on the device version, the pointer thermometer measures the oil temperature or determines the winding temperature in power transformers, distribution transformers or reactors. The temperature sensor of the pointer thermometer is located in the thermometer pocket mounted in the transformer tank. The measured value is displayed directly on the pointer thermometer.

4 Product description

Depending on the device version, you can use the following interfaces for transmitting measured values:

- Type TT: Passive 4...20 mA analog output
- Type TTM (24 VDC power supply necessary):
 - Active 4...20 mA analog output
 - RS485 interface for Modbus RTU

In addition, the contacts of the micro-switches switch when threshold values are exceeded.

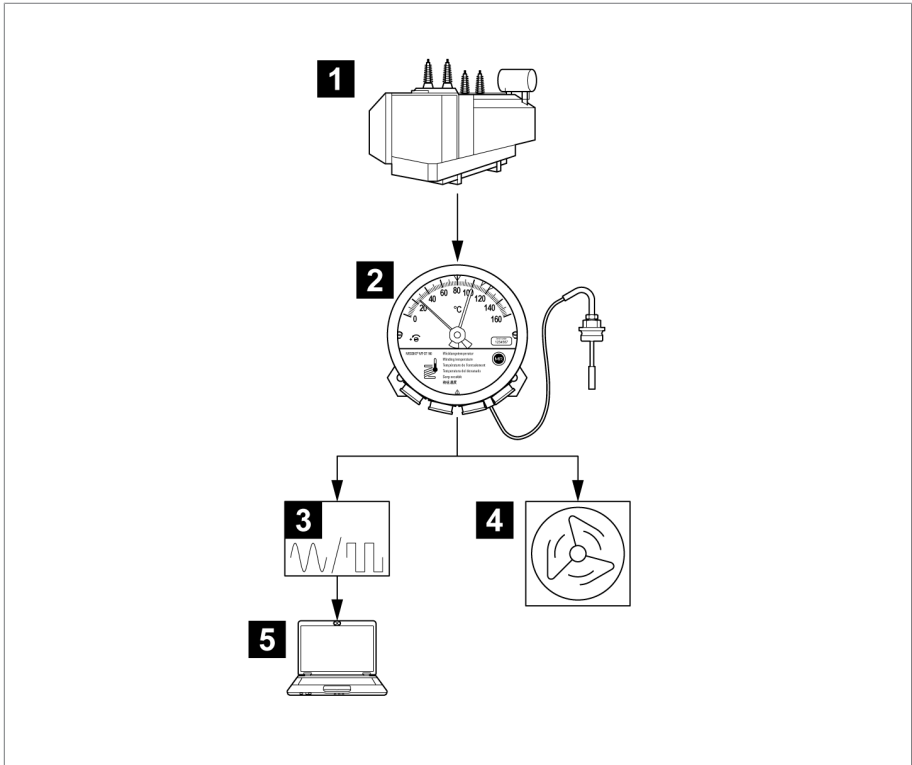

Figure 1: Example temperature measurement and temperature display

1 Transformer

2 Pointer thermometer for winding temperature (or oil temperature)

3 Digital display / analog display

4 Transformer cooling system control

5 SCADA

4.3 Design

4.3.1 Compact Standard overview

Depending on your order, the pointer thermometer features cable glands or NPT adapters.

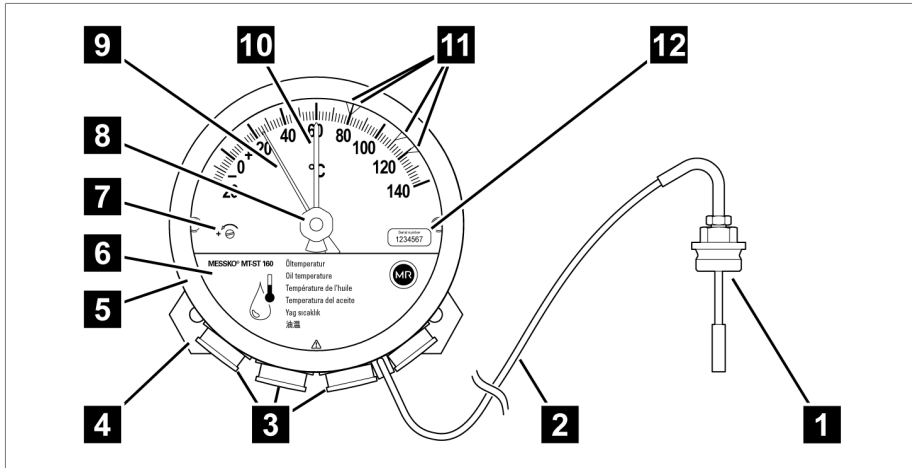

Figure 2: Pointer thermometer

1 Temperature sensor	2 Capillary line
3 Cable glands/adapters	4 Vibration-damping plate
5 Bayonet seal ring, glass pane and gasket	6 Cover plate
7 Calibration screw	8 Drag hand reset
9 Pointer	10 Drag hands
11 Adjustable micro-switches	12 Label with serial number



The pointer thermometer is calibrated at the factory. Do not adjust the calibration screw **7**, or else the device's warranty will be voided!

4 Product description

4.3.2 Overview Compact RM

Depending on your order, the pointer thermometer features an ANSI or M connector, cable glands or NPT adapters.

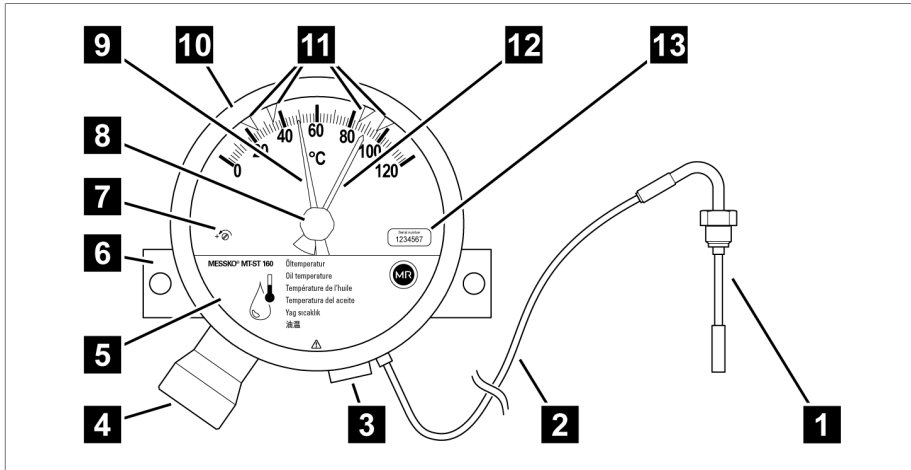

Figure 3: Pointer thermometer

1 Temperature sensor	2 Capillary line
3 Adapter	4 Connector plug
5 Cover plate	6 Mounting plate
7 Calibration screw	8 Drag hand reset button
9 Pointer	10 Bayonet seal ring
11 Micro-switches	12 Drag hands
13 Label with serial number	



The pointer thermometer is calibrated at the factory. Do not adjust the calibration screw **7**, or else the device's warranty will be voided!

4.3.3 Cable glands/adapters

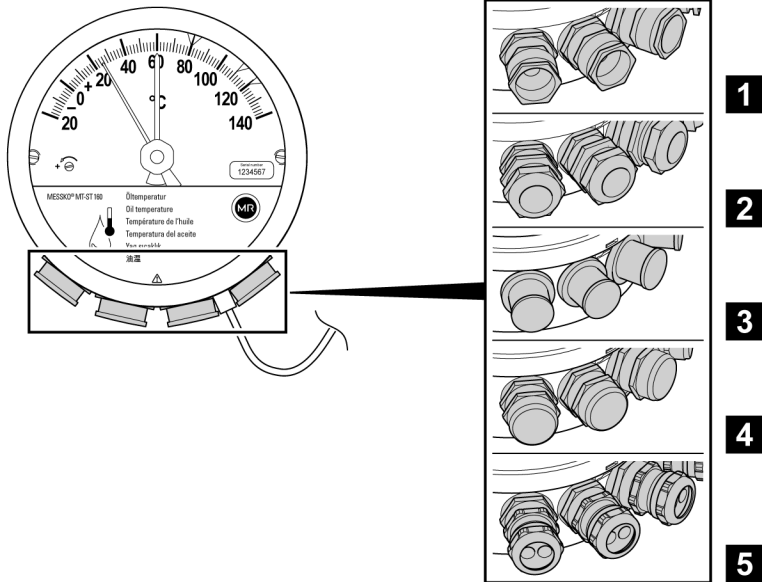

Figure 4: Cable glands

1 Standard cable gland

2 WADI cable gland

3 1/2" 14NPT adapter

4 3/4" 14NPT adapter

5 EMC double cable gland, available as an accessory: material no. 10173481

4 Product description

4.3.4 Ventilation

The pointer thermometer features ventilation to prevent the formation of condensate.

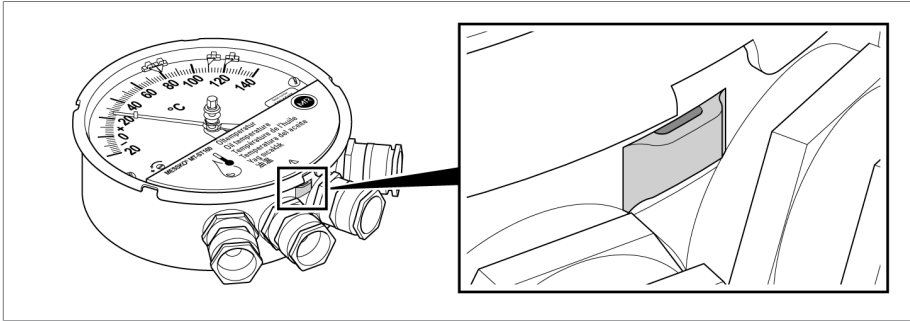

Figure 5: Ventilation

4.3.5 Overview Compact temperature sensor

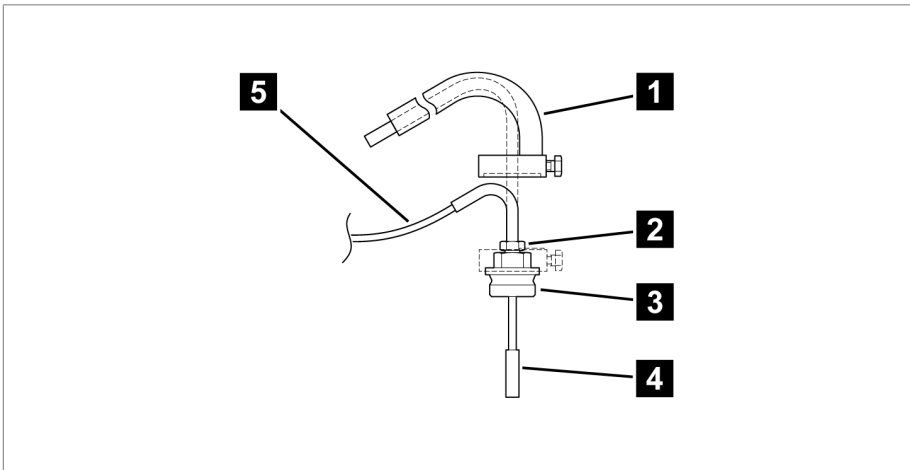

Figure 6: Temperature sensor

- | | |
|--|--|
| 1 Step protection (optional) * | 2 Small screw connection on temperature sensor |
| 3 Large screw connection on temperature sensor * | 4 Temperature sensor |
| 5 Capillary line | |

*) only for No. 6 VA and No. 7 sensors [► Section 12.3, Page 111]

4.4 Device versions

These operating instructions apply to the device versions of the MESSKO® Compact pointer thermometer illustrated in the following overview. These device versions are available both for the MESSKO® Compact Standard version (with cable glands) and for the MESSKO® Compact RM version (with plug connection).

Device version	Type key	Meaning
MESSKO® Compact Standard	MTST160..., without "RM"	With cable glands
MESSKO® Compact RM	MTST160...RM	With plug connection (e.g. ANSI connector)
Oil temperature indicator	MTST160SK/...(RM)	Without interface
	MTST160SK/TT/...(RM)	Passive 4...20 mA analog output
	MTST160SK/TTM/...(RM)	Active 4...20 mA analog output and Modbus RTU
Winding temperature indicator	MTST160W...	Gradient setting by heating current
	MTST160WR...	Gradient setting by resistance value
	MTST160W(R)/...(RM)	Without interface
	MTST160W(R)/TT/...(RM)	Passive 4...20 mA analog output
	MTST160W(R)/TTM/...(RM)	Active 4...20 mA analog output and Modbus RTU

Table 4: Abbreviations in the device designation

4 Product description

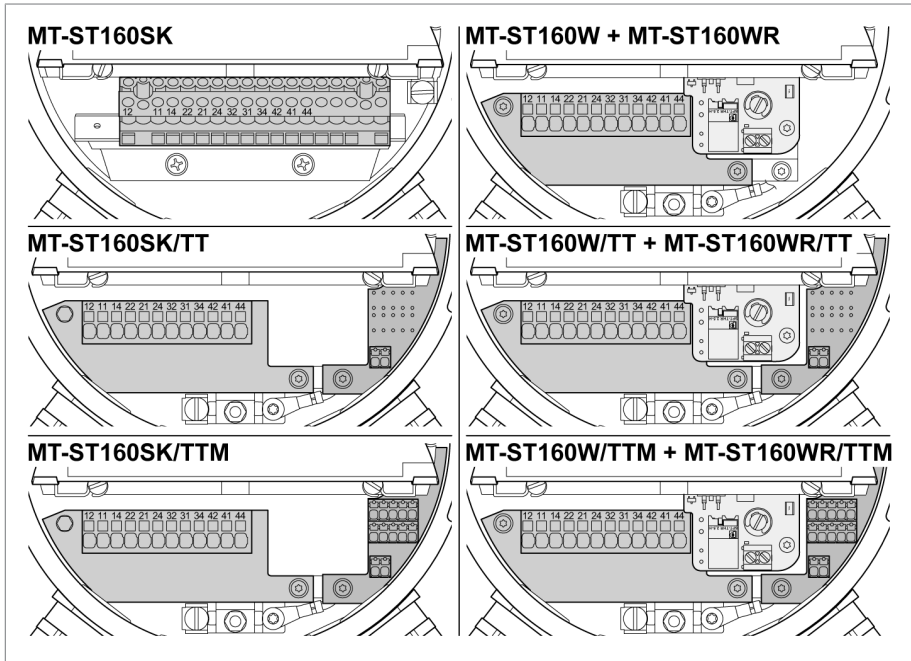

Figure 7: Device versions overview

Oil temperature indicator

- Display of the oil temperature.
- Pointer thermometer with adjustable micro-switches.
- The displayed temperature corresponds to the oil temperature at the temperature sensor of the pointer thermometer.
- The mechanical measurement system functions independently and without a power source.

Winding temperature indicator

- Display of the winding temperature.
- Pointer thermometer with adjustable micro-switches.

4 Product description

- The displayed temperature corresponds to the winding temperature based on the oil temperature, secondary transformer current and the temperature difference.
- The secondary transformer current supplies a heating resistor in the mechanical pointer thermometer with power, thus causing a temperature increase that corresponds to the loading of the transformer, as compared to the actual oil temperature that was measured.

Type TT

The pointer thermometer transmits the measured temperature via a passive 4...20 mA analog output.

You will find information on the electrical connection in the section Connecting the interfaces [► Section 6.4.6, Page 62].

Type TTM

The pointer thermometer transmits the measured temperature via an active 4...20 mA analog output and/or an RS485 interface for Modbus RTU.



The device needs a 24 VDC power supply for this. This is also the case even if you only connect the 4...20 mA analog output.

You will find information on the electrical connection in the section Connecting the interfaces [► Section 6.4.6, Page 62].

4 Product description

4.5 Safety markings

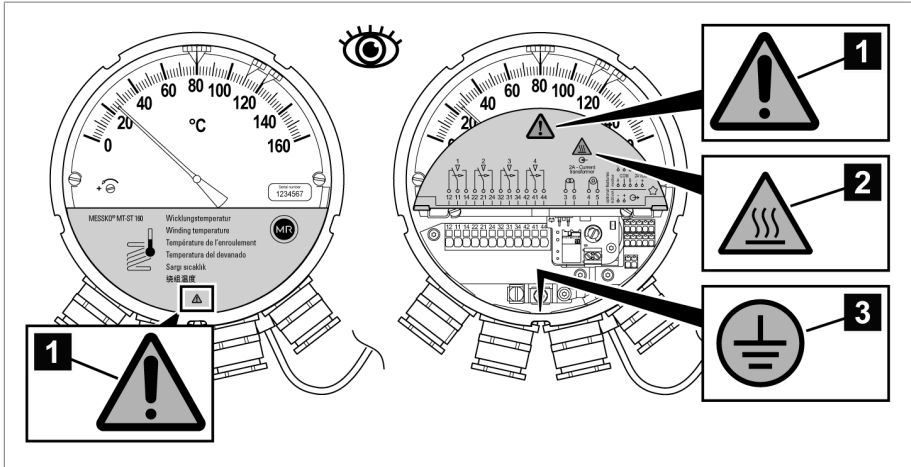

Figure 8: Safety markings

1 Observe the documentation

2 Caution: Risk of burns

(on the winding temperature indicator)

3 Protective conductor connection

[▶ Section 6.4.5.1, Page 59]

4 Product description

Additional safety marking for the Compact RM

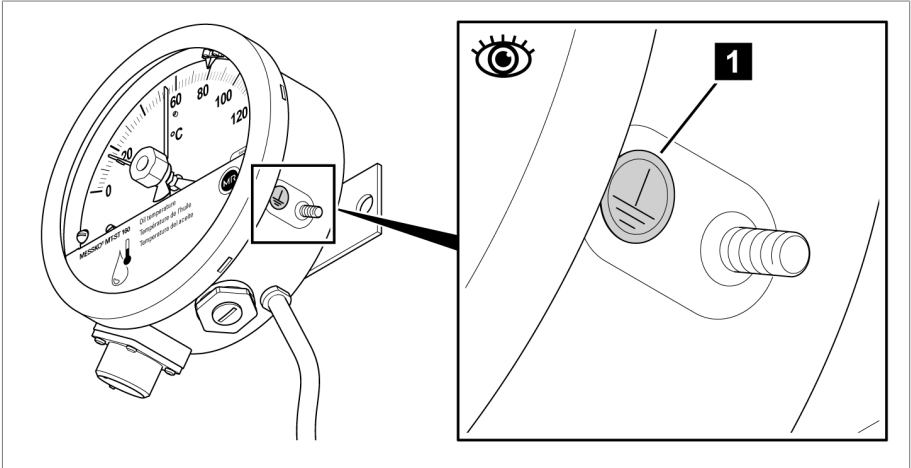

Figure 9: Additional safety marking for the Compact RM

- 1 Protective conductor connection
▶ Section 6.4.5.3, Page 60

4.6 Nameplate

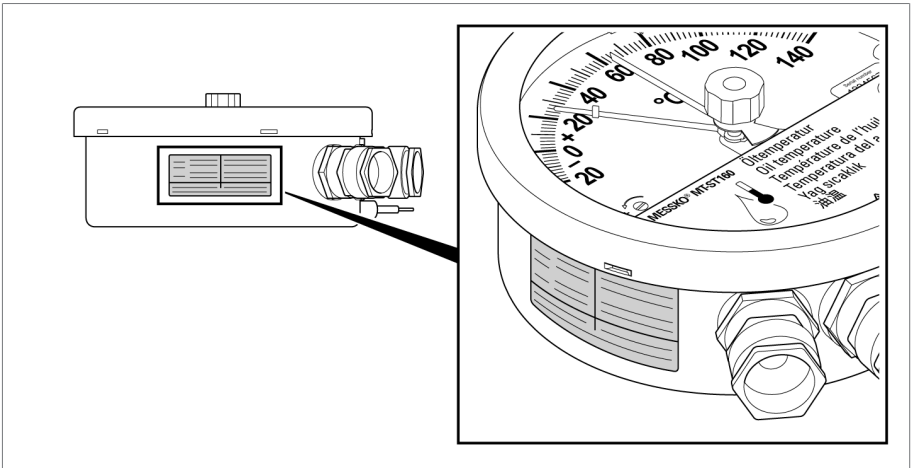

Figure 10: Nameplate

5 Packaging, transport and storage

5.1 Purpose

The packaging is designed to protect the packaged product during transport, loading, unloading and during periods of storage in such a way that no detrimental changes occur. The packaging must protect the goods against permitted transport stresses such as vibration, knocks and moisture (rain, snow, condensation).

The packaging also prevents the packaged goods from moving impermissibly within the packaging.

5.2 Suitability, structure and production

The goods are packaged in a sturdy cardboard box or solid wooden crate. These ensure that the shipment is secure when in the intended transportation position and that none of its parts touch the loading surface of the means of transport or touch the ground after unloading.

Inlays inside the box or crate stabilize the goods, preventing impermissible changes of position and protecting them from vibration.

5.3 Markings

The packaging bears a signature with instructions for safe transport and correct storage. The following symbols apply to the shipment of non-hazardous goods. Adherence to these symbols is mandatory.



Protect against moisture

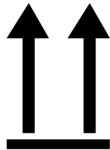

Top



Fragile



Attach lifting gear here



Center of mass

Table 5: Shipping pictograms

5.4 Transportation, receipt and handling of shipments

In addition to vibrations, jolts must also be expected during transportation. In order to prevent possible damage, avoid dropping, tipping, knocking over and colliding with the product.

Should the packaging tip over or fall, damage is to be expected regardless of the weight.

5 Packaging, transport and storage

Every delivered shipment must be checked for the following by the recipient before acceptance (acknowledgment of receipt):

- Completeness based on the delivery slip
- External damage of any type.

The checks must take place after unloading when the cartons or transport container can be accessed from all sides.

Visible damage

If external transport damage is found upon receipt of the shipment, proceed as follows:

- Immediately record the transport damage found in the shipping documents and have this countersigned by the carrier.
- In the event of severe damage, total loss or high damage costs, immediately notify the manufacturer's sales department and the relevant insurance company.
- After identifying damage, do not modify the condition of the shipment further and retain the packaging material until an inspection decision has been made by the transport company or the insurance company.
- Record the details of the damage immediately on site together with the carrier involved. This is essential for any claim for damages.
- If possible, photograph damage to packaging and packaged goods. This also applies to signs of corrosion on the packaged goods due to moisture inside the packaging (rain, snow, condensation).
- Be absolutely sure to also check the sealed packaging.

Hidden damage

When damage is not determined until unpacking after receipt of the shipment (hidden damage), proceed as follows:

- Make the party responsible for the damage liable as soon as possible by telephone and in writing, and prepare a damage report.
- Observe the time periods applicable to such actions in the respective country. Inquire about these in good time.

With hidden damage, it is very hard to make the transportation company (or other responsible party) liable. Any insurance claims for such damage can only be successful if relevant provisions are expressly included in the insurance terms and conditions.

5 Packaging, transport and storage

5.5 Storage of shipments

When selecting and setting up the storage location, ensure the following:

- Store the product and accessories in the original packaging until installation.
- Protect stored goods against moisture (rain, flooding, water from melting snow and ice), dirt, pests such as rats, mice, termites etc. and against unauthorized access.
- Store crates and boxes on pallets, timber beams or planks as protection against ground moisture and for improved ventilation.
- Ensure that the foundation has sufficient load-bearing capacity.
- Keep entrance paths clear.
- Check the stored goods at regular intervals. Also take appropriate action after storms, heavy rain or snow etc.

5.6 Further transport

Use the original product packaging for further transport.

If you transport the product to the final installation site in a mounted state, observe the following information in order to protect the product against mechanical damage due to external influences.

Transport packaging requirements

- Select packaging suitable for the duration of transport or storage, taking the climatic conditions into consideration.
- Ensure that the packaging protects the product against transport stress such as shaking, vibrations and impacts.
- Ensure that the packaging protects the product against moisture such as rain, snow and condensation.
- Ensure that the packaging allows for sufficient air circulation in order to prevent the formation of condensation.

6 Installation and commissioning

This chapter describes how to mount and connect the device correctly. Observe the following hazard notices prior to opening the device:

⚠ DANGER



Electric shock!

Risk of fatal injury due to electrical voltage. Always observe the following safety regulations when working in or on electrical equipment.

- ▶ Disconnect the equipment.
- ▶ Lock the equipment to prevent an unintentional restart.
- ▶ Make sure all poles are de-energized.
- ▶ Ground and short-circuit.
- ▶ Cover or cordon off adjacent energized parts.

⚠ CAUTION



Risk of injury and damage to the device

The measurement system is hermetically sealed. If you cut the capillary line, harmful liquid can escape and the measurement system will be destroyed.

- ▶ Never cut the capillary line.
- ▶ Do not damage the capillary lines or sensors.

NOTICE

Damage to the device!

Electrostatic discharge can lead to damage to the device.

- ▶ Take precautionary measures to prevent the build-up of electrostatic charges on work surfaces and personnel.

6 Installation and commissioning

NOTICE

Damage to the device!

If you kink the capillary line or carry the device by the capillary line, the device can become damaged and display incorrect measured values as a result.

- ▶ Carefully remove the device from the packaging.
- ▶ Never carry the device by the capillary line.
- ▶ Do not damage the capillary line and sensor.
- ▶ Unroll the capillary line without bending or kinking it.
- ▶ Observe the minimum bending radius of 50 mm.

6.1 Transporting in the installed state

If transportation of the entire assembled unit is necessary between mounting the device onto the transformer / oil conservator and commissioning it, please also refer to the information on further transport [▶ Section 5.6, Page 30].

NOTICE

Damage to the device

The device can become damaged during transport due to unsuitable packaging.

- ▶ Use suitable packaging for transporting the device in the installed state.
- ▶ Protect the device against mechanical damage.
- ▶ Prevent the ingress of rain water.
- ▶ Ensure sufficient air ventilation without the formation of condensation.

6.2 Checking measured temperature values

Before attaching the pointer thermometer, you can check the accuracy of the display with a reference measurement. The pointer thermometer is calibrated at the factory.

- ✓ Only perform a reference measurement in moving liquid baths. We recommend using the Messko® MZT1650S calibration bath.
- ✓ The temperature of the liquid bath must remain constant for 15 minutes.
- ✓ Use an additional, calibrated glass thermometer to perform the reference measurement.

6 Installation and commissioning

1. Immerse the temperature sensor of the pointer thermometer and a calibrated glass thermometer in the liquid bath for approx. 15 minutes.
 2. Compare the measured temperature values of the pointer thermometer and glass thermometer with each other.
- ⇒ If the measured temperature values deviate from each other significantly (maximum permitted deviation $\pm 3\text{ }^{\circ}\text{C}$), contact the service department of Maschinenfabrik Reinhausen GmbH [► Section 2.3, Page 14].

6.3 Mounting the pointer thermometer

6.3.1 Attaching the pointer thermometer to the transformer

When attaching the thermometer to the transformer, note the following information:

- Ensure that the pointer thermometer is mounted vertically.

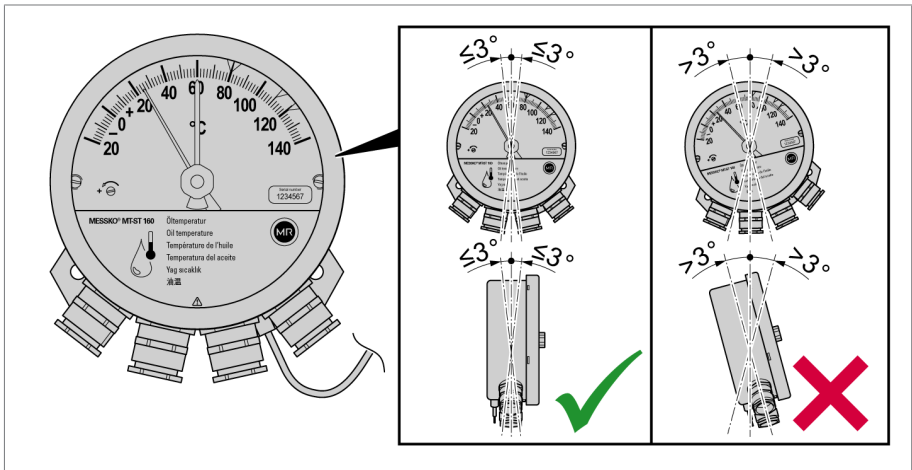

Figure 11: Mounting position

- Ensure that the pointer thermometer is not subjected to any vibrations at the installation location.
- Comply with EMC standards [► Section 6.4.1.1, Page 43].
- Observe the dimensions in the chapter Technical data [► Section 11, Page 101].

6 Installation and commissioning

6.3.1.1 Attaching the Compact Standard pointer thermometer

You can use the following screws to attach the pointer thermometer:

- M8 hexagon screws or cylinder screws.
- Use a screw length that is appropriate based on the installation situation.

To attach the pointer thermometer to the transformer, proceed as follows:

1. Drill two holes, with a distance of 140 mm (5.51") and a diameter of 9 mm (0.35"), into a suitable bracket on the outside of the transformer, on the control cabinet mounting plate or on another suitable structure.

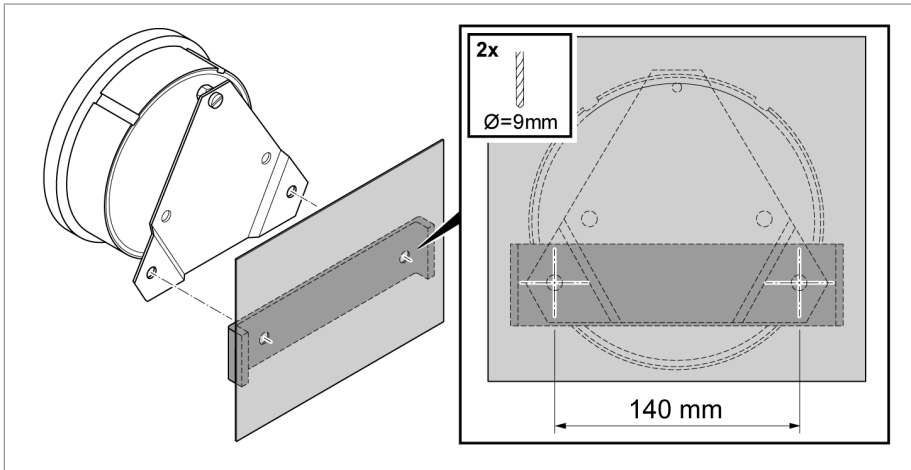

Figure 12: Holes

6 Installation and commissioning

2. Attach the pointer thermometer with vibration-damping plate to the transformer.

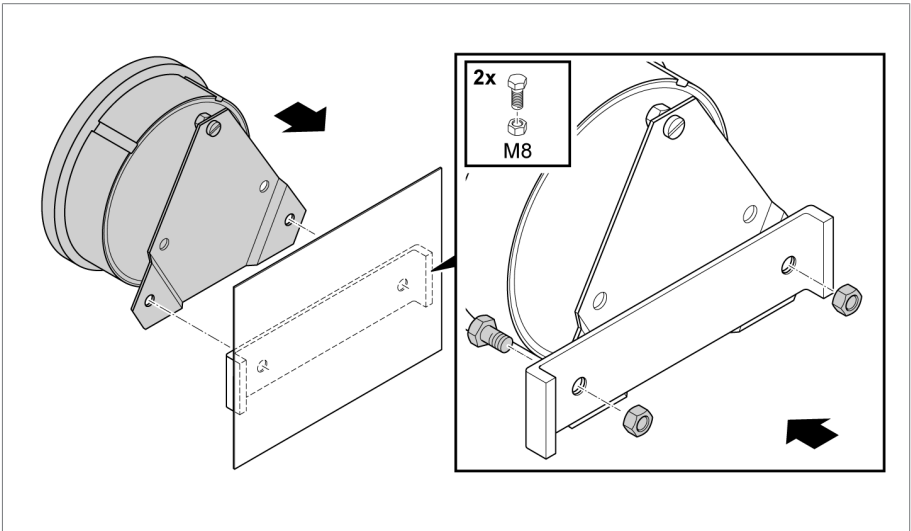

Figure 13: Attaching the pointer thermometer with vibration-damping plate

6.3.1.2 Attaching the Compact RM pointer thermometer

You can use the following screws to attach the pointer thermometer:

- M12 hexagon screws or cylinder screws (as an alternative, also 7/16-14 UNC).
- Use a screw length that is appropriate based on the installation situation.

6 Installation and commissioning

To attach the pointer thermometer to the transformer, proceed as follows:

1. Drill two holes, with a distance of 184 mm (7.24") and a diameter of 12.5 mm (0.49"), in a suitable bracket on the outside of the transformer, on the control cabinet mounting plate or on another suitable structure.

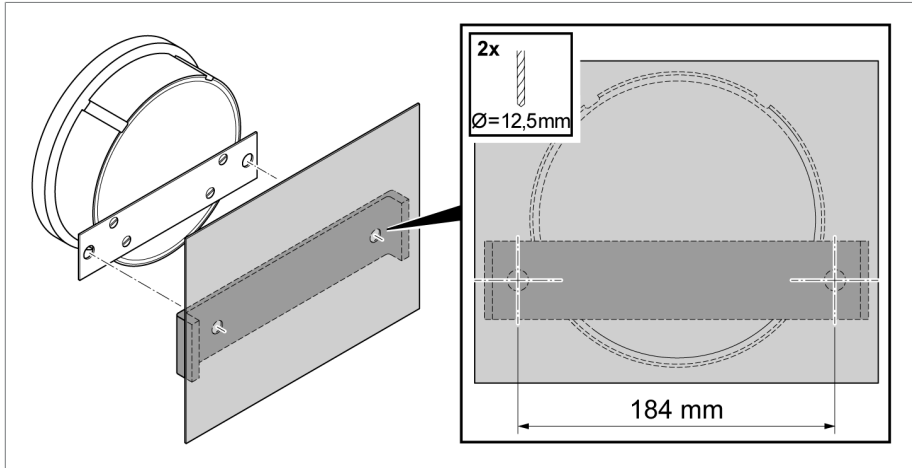

Figure 14: Holes

2. Attach the pointer thermometer with mounting plate to the transformer.

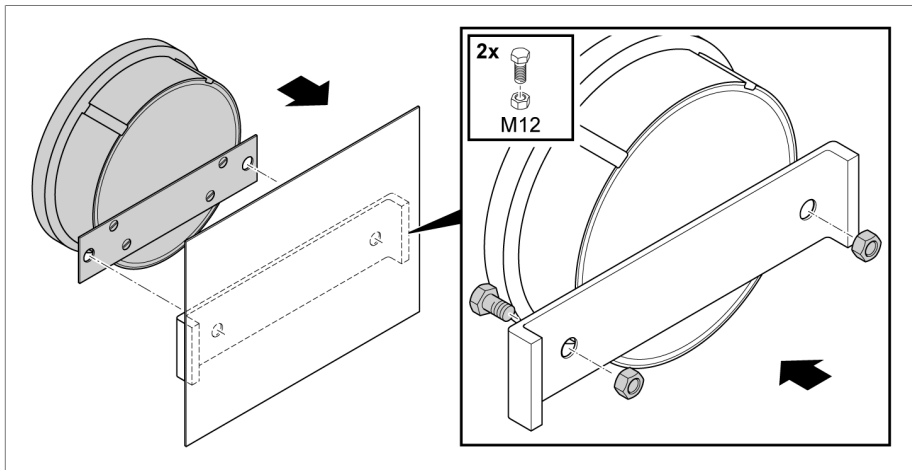

Figure 15: Attaching the pointer thermometer with mounting plate

6 Installation and commissioning

6.3.2 Securing the capillary line

When securing the capillary line, note the following information:

NOTICE

Damage to the device!

A capillary line bending radius that is too narrow can lead to a loss of device function!

- ▶ Ensure compliance with the minimum bending radius of 50 mm (1.97").
- Attach the capillary line to the transformer so that it cannot be damaged during transport or operation, due to factors such as impact, scuffing, pressure, vibrations or crushing.

Proceed as follows:

1. Route the capillary line to the transformer and secure it with cable ties.
2. Wind up any excess capillary line with a minimum winding diameter of 80 mm (3.15").

6.3.3 Inserting the temperature sensor

1. Fill 2/3 of the thermometer pocket of the transformer with oil or heat-conducting paste.

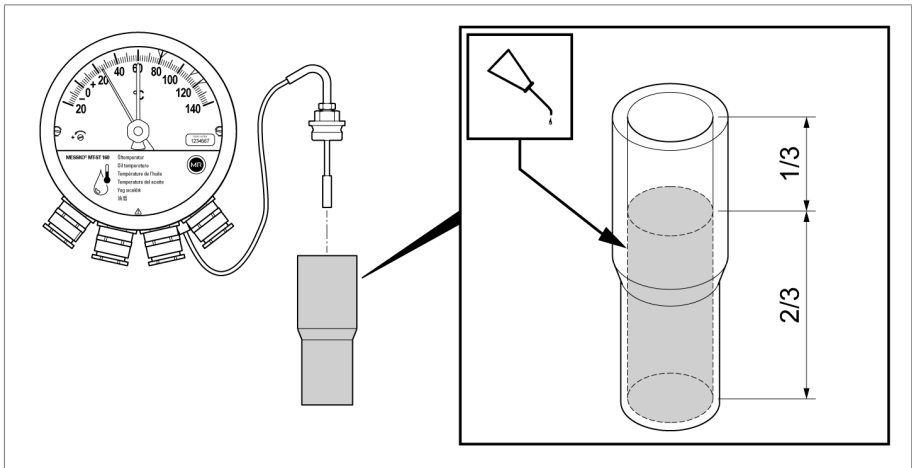

Figure 16: Filling the thermometer pocket

6 Installation and commissioning

2. Unscrew the large screw connection of the temperature sensor from the small screw connection.

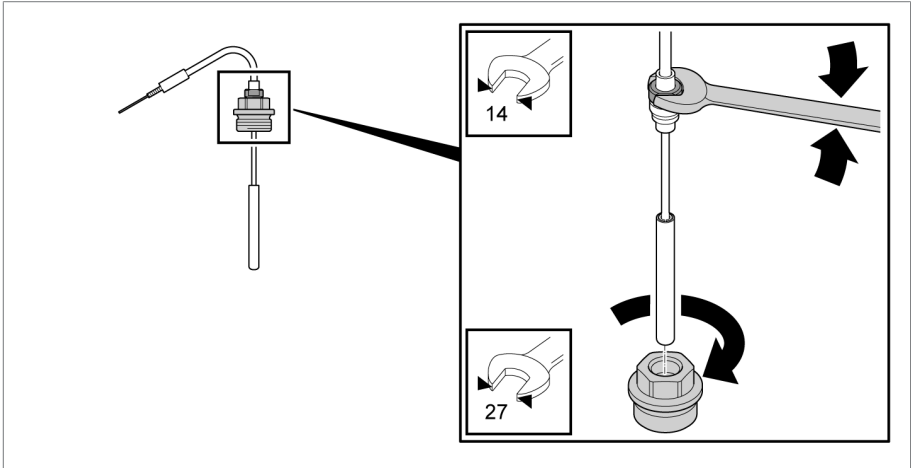

Figure 17: Unscrewing the large screw connection

3. Insert the large screw connection into the transformer thermometer pocket along with the gasket (gasket not included in the scope of delivery) and secure it.

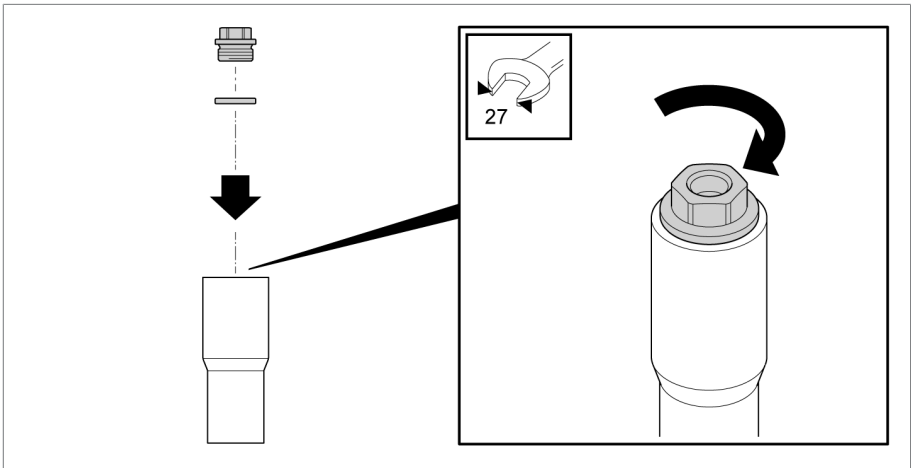

Figure 18: Securing the large screw connection

6 Installation and commissioning

4. Insert the temperature sensor into the large screw connection and turn it to the desired position together with the capillary line. Tighten the small screw connection of the thermometer sensor.

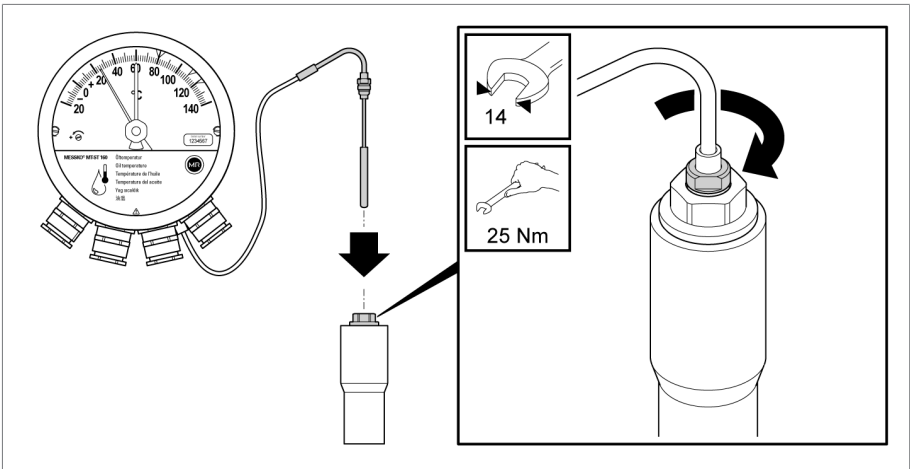

Figure 19: Inserting and securing the temperature sensor



When using the offshore variant of the temperature sensor (No. 6 VA), be aware of the wrench sizes and torque specifications that deviate [► Section 12.3, Page 111] from the standard variant.

6 Installation and commissioning

6.3.4 Inserting the No. 7 RM temperature sensor

- Ensure that the temperature sensor is dry or a small amount of conductive paste is applied to it, and insert it into the thermometer sleeve, align it and secure it using the screw connection.

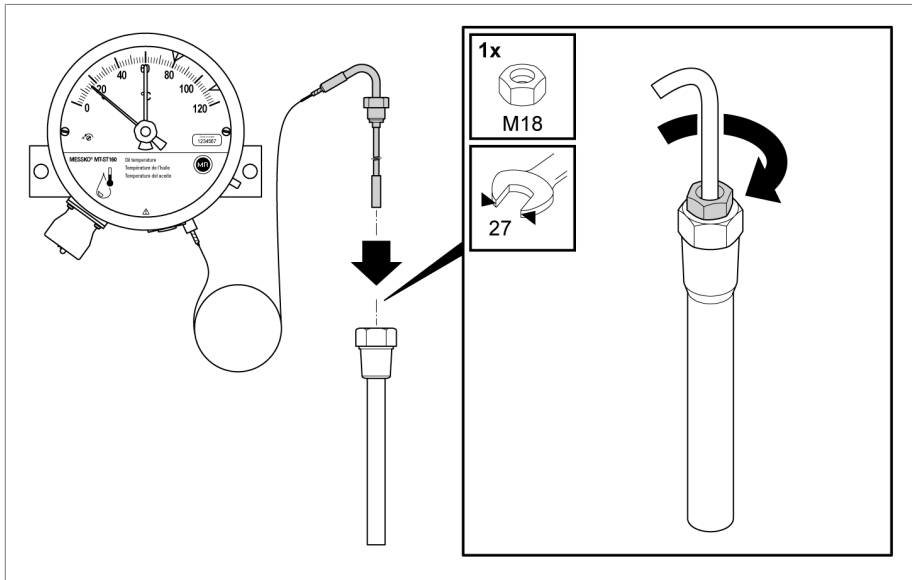

Figure 20: Inserting and securing the temperature sensor

6 Installation and commissioning

6.3.5 Attaching the step protection (optional)

You can equip the capillary line for No. 6 VA and No. 7 sensors [► Section 12.3, Page 111] with step protection.

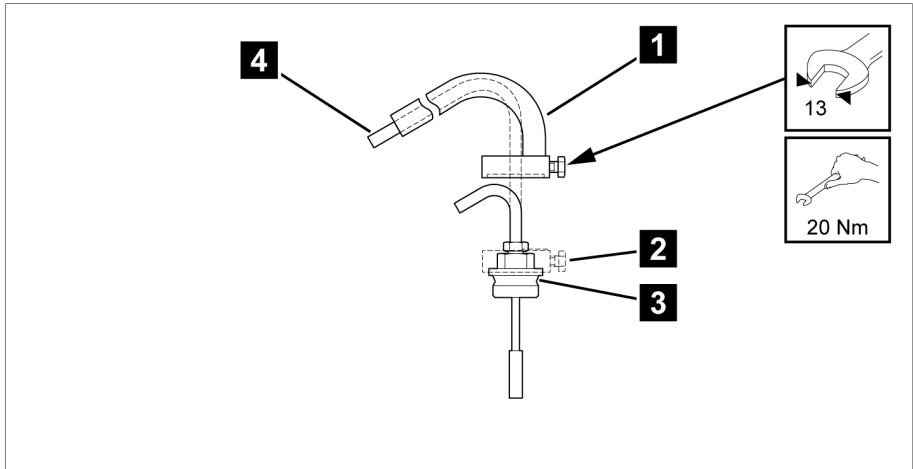

Figure 21: Step protection

1 Step protection	2 Fixing screw
3 Large screw connection	4 Capillary line

1. Place the step protection **1** on the large screw connection **3** of the temperature sensor.
2. Route the capillary line **4** inside the step protection **1**.
3. Tighten the fixing screw **2** of the step protection to the wrench flat of the large screw connection **3**.

6 Installation and commissioning

6.4 Electrical connection

⚠ DANGER



Electric shock!

Danger of death due to electrical voltage when assembling/disassembling the device.

- ▶ Switch off transformer on high-voltage side and low-voltage side.
- ▶ Lock transformer to prevent unintentional restart.
- ▶ Make sure that everything is de-energized.
- ▶ Visibly connect all transformer terminals to ground (grounding leads, grounding disconnectors) and short circuit them.
- ▶ Cover or cordon off adjacent energized parts.

⚠ WARNING



Electric shock!

Too small bending radii could damage the insulation of cables or cores.

- ▶ Observe bending radii for the cables and their cores according to the manufacturer's instructions.

⚠ WARNING



Fire hazard!

There is a fire hazard if the conductor material is not suitable for the terminals. This can lead to severe burns and property damage.

- ▶ Use copper conductors only.

⚠ CAUTION



Risk of burns!

Danger of bodily injuries due to heat!

- ▶ Winding temperature indicator: The potentiometer and the surfaces in the vicinity can heat up considerably due to the CT current. Do not touch this area.

NOTICE

Damage to the device!

Electrostatic discharge can lead to damage to the device.

- ▶ Take precautionary measures to prevent the build-up of electrostatic charges on work surfaces and personnel.

6.4.1 Preparation

Observe the following information for the electrical connection.

6.4.1.1 Electromagnetic compatibility

The device has been developed in accordance with the applicable EMC standards. The following points must be noted in order to maintain the EMC standards.

6.4.1.1.1 Wiring requirement of installation site

Note the following when selecting the installation site:

- The system's overvoltage protection must be effective.
- The system's ground connection must comply with all technical regulations.
- Separate system parts must be joined by a potential equalization.

6.4.1.1.2 Wiring requirement of operating site

Note the following when wiring the operating site:

- Do not route lines which cause interference (e.g. supply lines) and lines susceptible to interference (e.g. signal lines) in the same cable duct.
- Maintain a distance of more than 100 mm (3.94") between lines which cause interference and those which are susceptible to interference.
- Never connect the device with a multi-wire collective pipe.
- Use shielded cables for signal transmission.

6.4.1.2 Safeguarding the power circuits

You may only connect the device to circuits with an external overcurrent protective device and an all-pole isolating device so that the equipment can be fully de-energized if required.

6 Installation and commissioning

Suitable equipment includes isolating devices in accordance with IEC 60947-1 and IEC 60947-3 (e.g. circuit breakers). Observe the properties of the relevant circuits (voltage, maximum currents) when selecting the circuit breaker type. In addition, observe the following:

- It must be easy for the operator to access the isolating device.
- The isolating device must be labeled for the device and the circuits to be isolated.
- The isolating device may not be a part of the power line.
- The isolating device may not interrupt the main protective conductor.

Miniature circuit breaker

You must protect the mains circuits for the main switching contacts with a 6 A miniature circuit breaker with triggering characteristic C.

Conductor cross-section

For all mains circuits, you must use a conductor cross-section that is appropriate for the miniature circuit breaker you have selected.

6.4.1.3 Cable recommendation

Please note the following recommendation from the manufacturer when wiring the device:

- Due to the intrinsic heating of the devices, the connection cables used for the winding temperature indicator version (MT-ST160W...) must have a temperature resistance that is 40 K higher than the operating temperature. Example: at an ambient temperature of +80 °C, the temperature resistance must be at least +120 °C.
- Due to the intrinsic heating of the devices, the connection cables used for the oil temperature indicator version (MT-ST160SK...) must have a temperature resistance that is 25 K higher than the operating temperature. Example: at an ambient temperature of +80 °C, the temperature resistance must be at least +105 °C.
- The cables used must be flame-resistant in accordance with IEC 60332-1-2 or UL 2556 VW-1.

6 Installation and commissioning

- If both low voltage and extra-low voltage are connected in the device, it must be ensured that the circuits for extra-low voltage and for low voltage in the connection area and in the cable are separated from each other with double insulation.
- Devices with a plug connection may be connected via the device plug to either only extra-low-voltage circuits or only low-voltage circuits.

Connection cable	Terminals	Permissible cross-section
Protective conductor		≥ all other conductors
Micro-switch for oil temperature indicator without interface MT-ST160SK	12, 11, 14; 22, 21, 24; 32, 31, 34; 42, 41, 44	1.5...2.5 mm ² /16...12 AWG
Micro-switch for oil temperature indicator with interface MT-ST160SK/TT MT-ST160SK/TTM	12, 11, 14; 22, 21, 24; 32, 31, 34; 42, 41, 44	0.2...4 mm ² /24...12 AWG
Micro-switch for all winding temperature indicators MT-ST160W MT-ST160WR	12, 11, 14; 22, 21, 24; 32, 31, 34; 42, 41, 44	0.2...4 mm ² /24...12 AWG
2 A current transformer for the winding temperature indicator ¹⁾	3, 6	0.2...4 mm ² /24...12 AWG
Measuring device for the winding temperature indicator ¹⁾ : Gradient setting via - voltmeter (MT-ST160W...) - ohmmeter (MT-ST160WR...)	4, 5	0.14...1.5 mm ² /26...16 AWG
Analog output ¹⁾ (types TT, TTM)	(+), (-)	0.2...1.5 mm ² /24...16 AWG
Power supply ¹⁾ (type TTM)	24 V, 0 V	0.2...1.5 mm ² /24...16 AWG
Modbus RTU ¹⁾ (type TTM)	A, COM, B	0.2...1.5 mm ² /24...16 AWG
A = "+" connection B = "-" connection COM = common ground		

Table 6: Recommendation for connection cable (standard connections)

¹⁾ Depending on the equipment version (optional)

It must be possible to apply a nominal voltage of at least 300 V to all above-listed connection cables. Rigid and flexible cables can be used.

6 Installation and commissioning

Modbus RTU

We recommend a shielded twisted pair cable. A shielded twisted pair cable is recommended. To optimize the number of cables and the cable glands, it may be advantageous to run Modbus and the 24 V supply in the same cable.

Connect the shield to the Modbus master (e.g. in the control cabinet) and route it to the device without interruption. We recommend EMC cable glands for shielding the device.

Analog output

We recommend a shielded cable.

Connect the shield in the control cabinet and route it to the device without interruption. We recommend EMC cable glands for shielding the device.

6.4.2 Removing the bayonet seal ring

Before connecting, setting or testing the pointer thermometer, the bayonet seal ring must be removed.

- ▶ Turn the bayonet seal ring counter-clockwise to the stop.

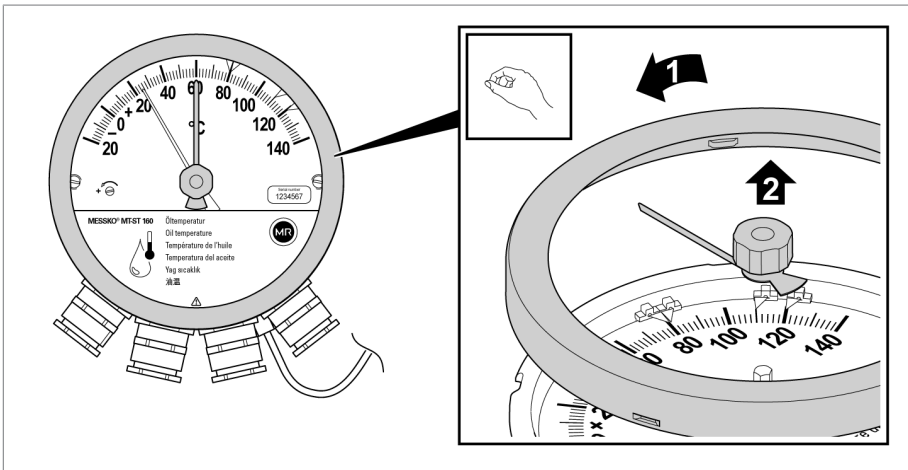

Figure 22: Removing the bayonet seal ring

- ▶ Lift off the bayonet seal ring along with the viewing glass and rubber gasket and place them safely on a clean, even storage surface.

6 Installation and commissioning

6.4.3 Opening the cover plate

The individual connection cables in the device are connected as shown in the diagram, which is printed on the inside of the cover plate.

- Open the cover plate.

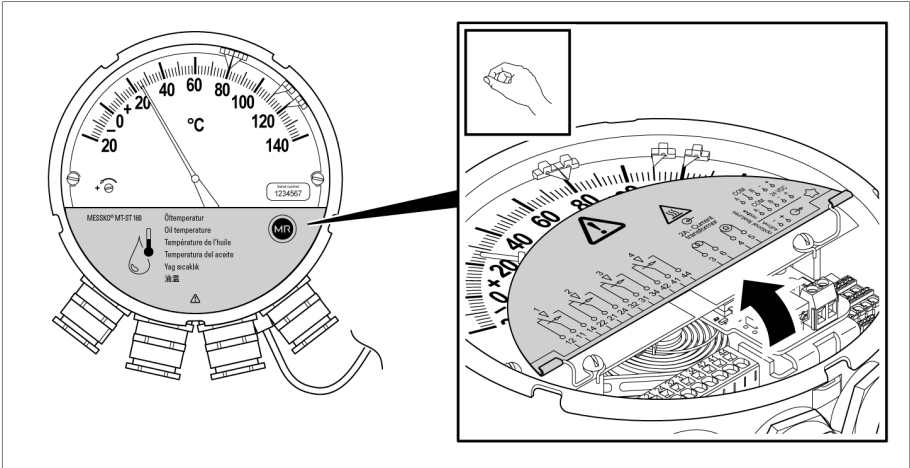

Figure 23: Opening the cover plate

6 Installation and commissioning

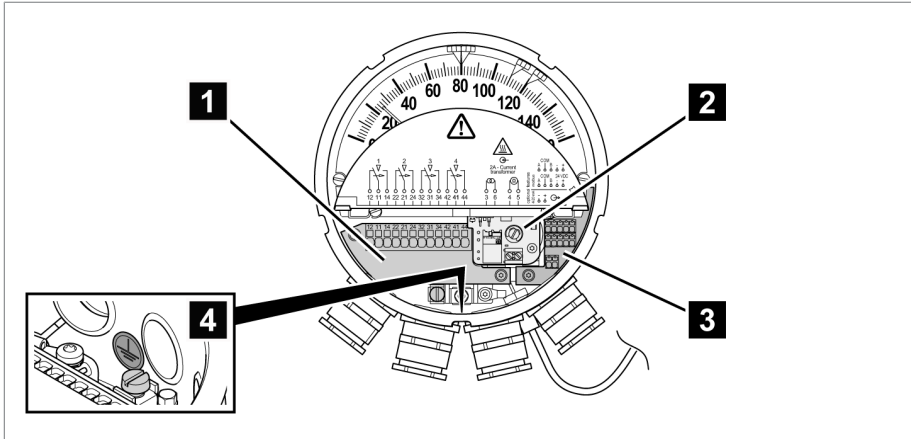

Figure 24: Cover plate open

1 Connections for micro-switches

2 Winding temperature indicator only: connections for current transformer and voltmeter (type W) or ohmmeter (type WR)

3 Optional connections for supply, 4...20 mA analog output and Mod-bus

4 PE

6 Installation and commissioning

6.4.4 Cable glands and adapters

- **NOTICE!** If cable glands or adapters are not used, these **must be sealed with suitable seals and metal locking screws to ensure the IP55 degree of protection and flame protection of the device.**

Metal locking screws are available as accessories:

- Brass locking screw: material no. MS960750
- Stainless steel locking screw: material no. 781711

For assembly, see Sealing cable glands/NPT adapters [► Section 6.4.8, Page 74].

Cable gland assignment

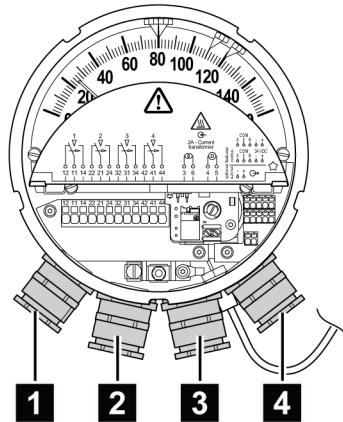

Figure 25: Cable gland assignment

Steps to perform	Assignment	Note
1	2x change-over contacts and PE	
2	2x change-over contacts	
3	Input (and output) for Modbus and supply voltage	EMC double cable gland
4	Input current transformer signal and 4...20 mA analog output	EMC double cable gland

Table 7: Example wiring (maximum assignment)

6 Installation and commissioning

6.4.4.1 Standard cable gland

1. Remove the locking screw on the adapter.

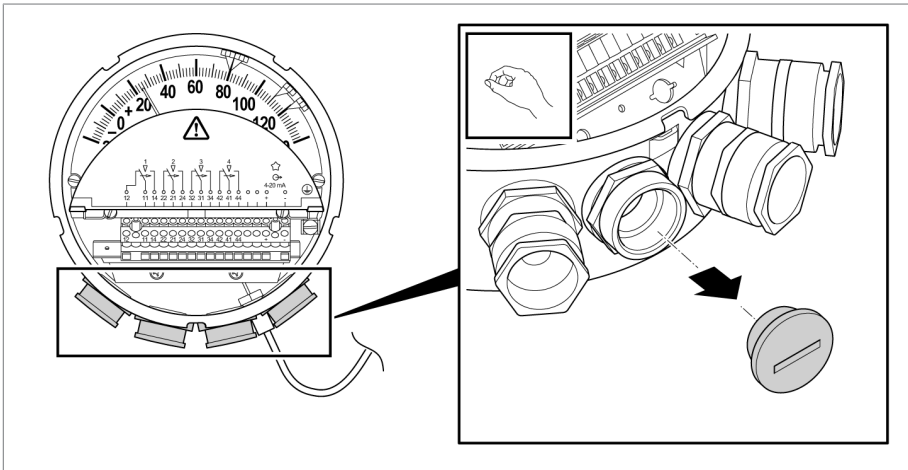

Figure 26: Removing the locking screw

2. Unscrew the provided cable gland and remove the dust protection disk.

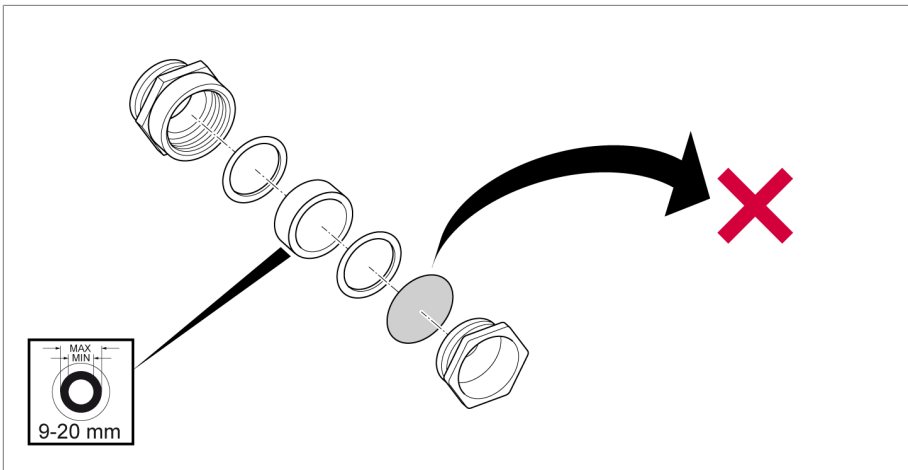

Figure 27: Removing the dust protection disk

6 Installation and commissioning

3. Route a sufficient length of connection cable through the cable gland and adapter and tighten the cable gland (see Cable gland dimensions)

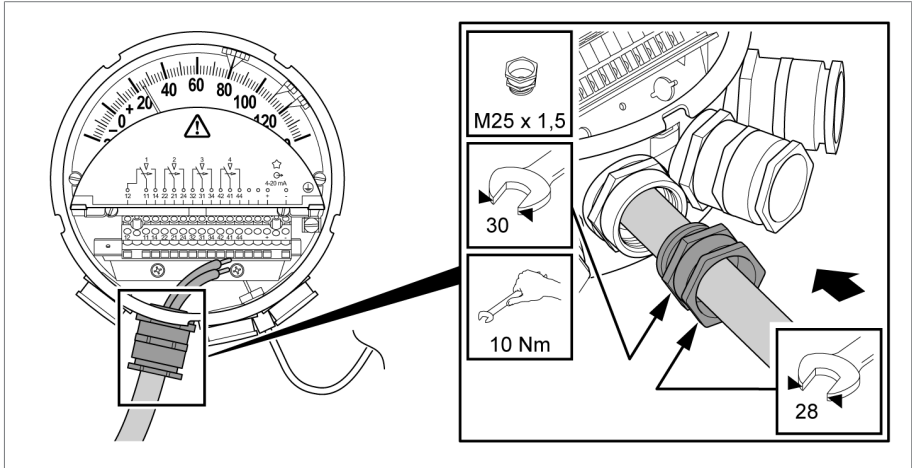

Figure 28: Cable gland

Also refer to

- Connecting cable glands/NPT adapters [► 74]

6.4.4.2 WADI cable gland (stainless steel or brass)

1. Remove the locking screw on the adapter.

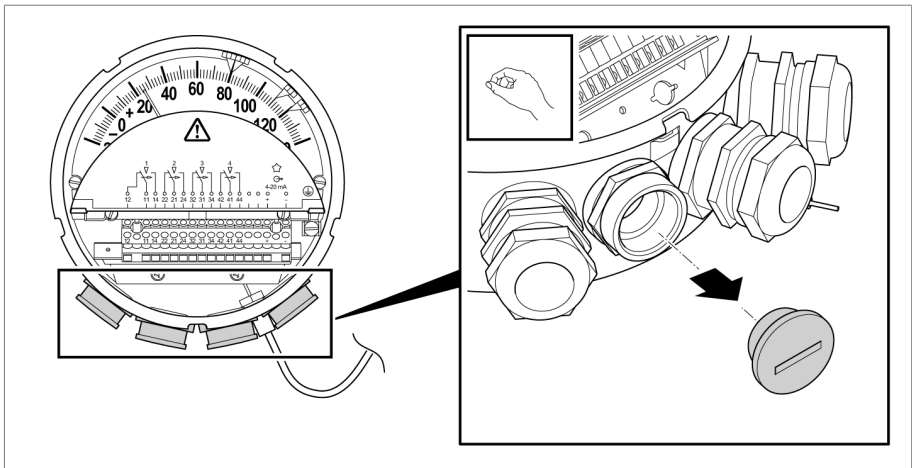

Figure 29: Removing the locking screw

6 Installation and commissioning

2. Unscrew the provided cable gland and remove the dust protection disk.

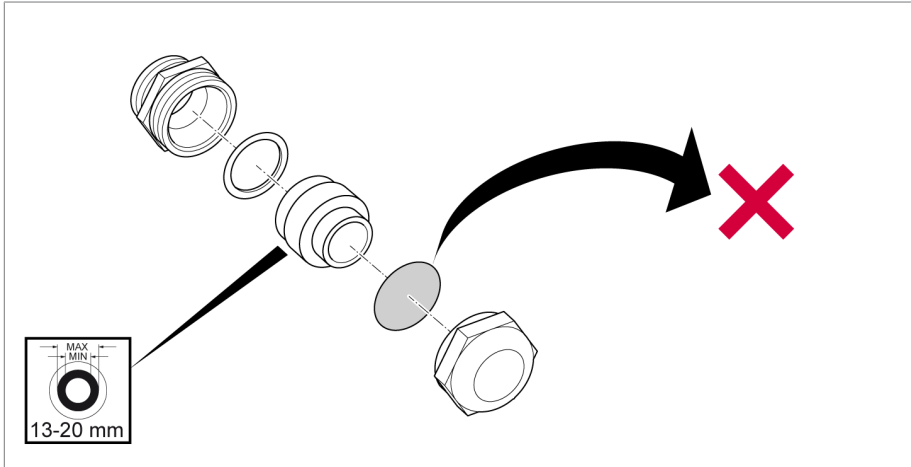

Figure 30: Removing the dust protection disk

3. Route a sufficient length of connection cable through the cable gland and adapter and tighten the cable gland.

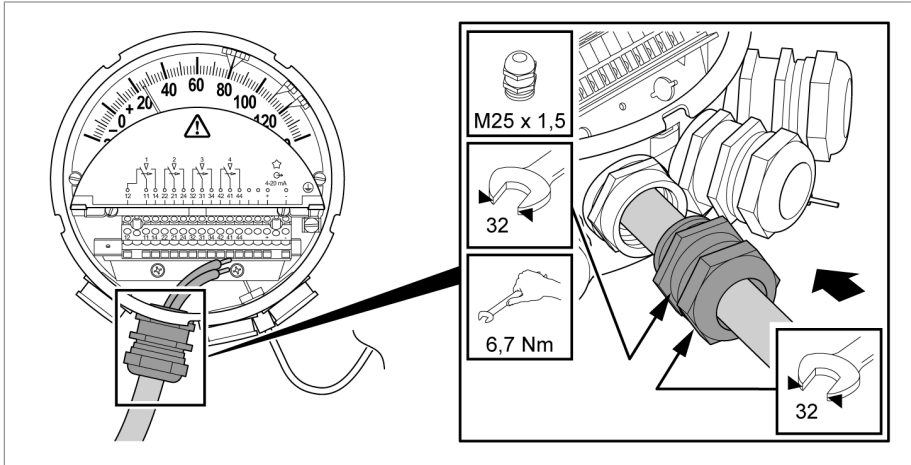

Figure 31: Cable gland

Also refer to

- Connecting cable glands/NPT adapters [► 74]

6 Installation and commissioning

6.4.4.3 Offshore cable gland (stainless steel)

1. Remove the locking screw on the adapter.

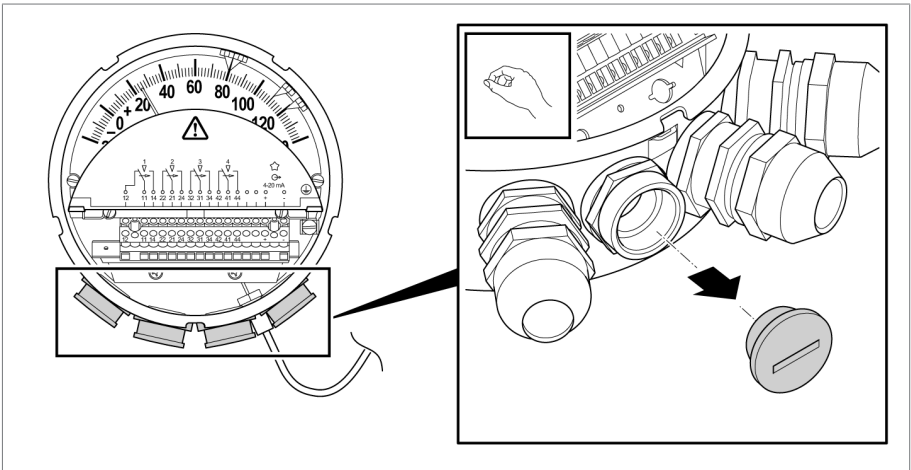

Figure 32: Removing the locking screw

2. Unscrew the provided cable gland and remove the dust protection disk.

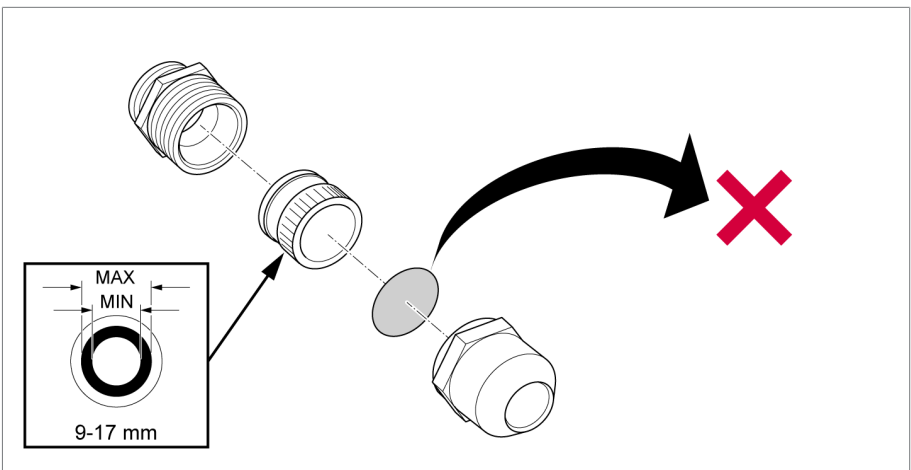

Figure 33: Removing the dust protection disk

6 Installation and commissioning

3. Route a sufficient length of connection cable through the cable gland and adapter and tighten the cable gland.

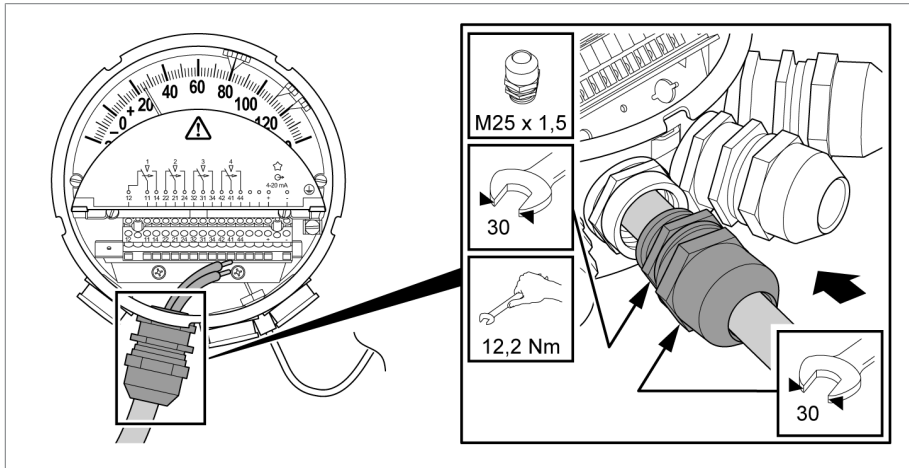

Figure 34: Cable gland

Also refer to

- Connecting cable glands/NPT adapters [► 74]

6.4.4.4 EMC double cable gland (accessory)

Use shielded conductors for the Modbus wiring and connect the shield on both sides (same shielding potential for all devices).

We recommend EMC cable glands, which are commercially available as EMC **single** cable glands.

Depending on the device version and choice of connection cables, using an EMC **double** cable gland may be useful. You can order these as accessories from Maschinenfabrik Reinhausen GmbH:

- EMC double cable gland: material no. 10173481

You will find the technical drawing for this EMC double cable gland in the appendix.



The EMC double cable gland is suitable for cables with an external diameter of 8.7 mm \pm 10%.

6 Installation and commissioning

Prepare the cables before inserting into the cable gland:

1. Strip a length of at least 15 mm of insulation from the cables.
2. Insulate the braid at the lower end with insulating tape.

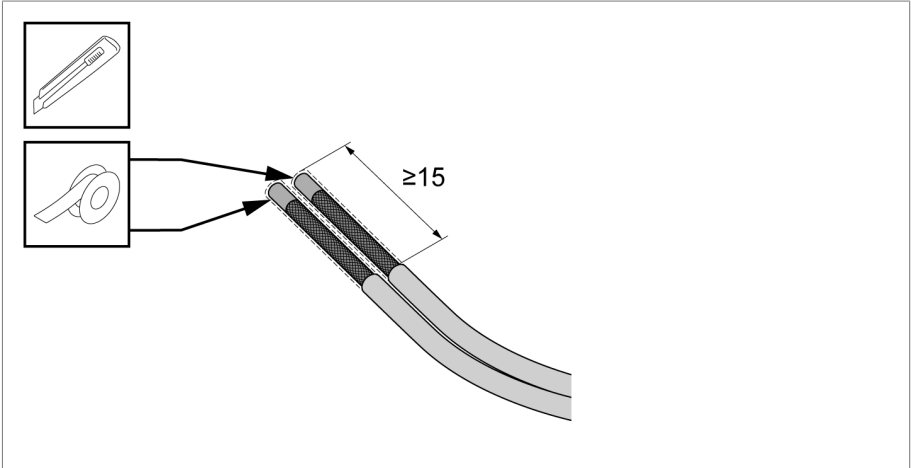

Figure 35: Stripping and insulating the cables

The cable gland can now be attached. To do so:

1. Gently twist the cables and feed through the openings in the cable gland.

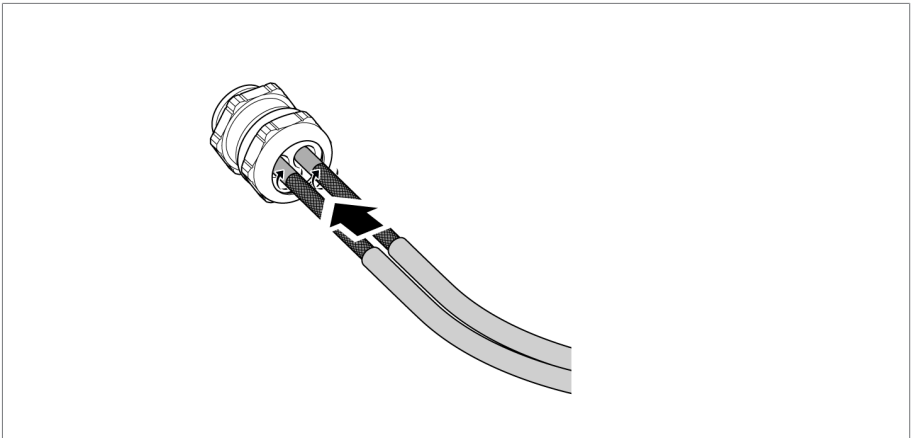

Figure 36: Inserting the cables

2. Feed the cables through until the cable sheath contacts the spring in the cable gland.

6 Installation and commissioning

3. Mark this position above the gland on the cable sheath.

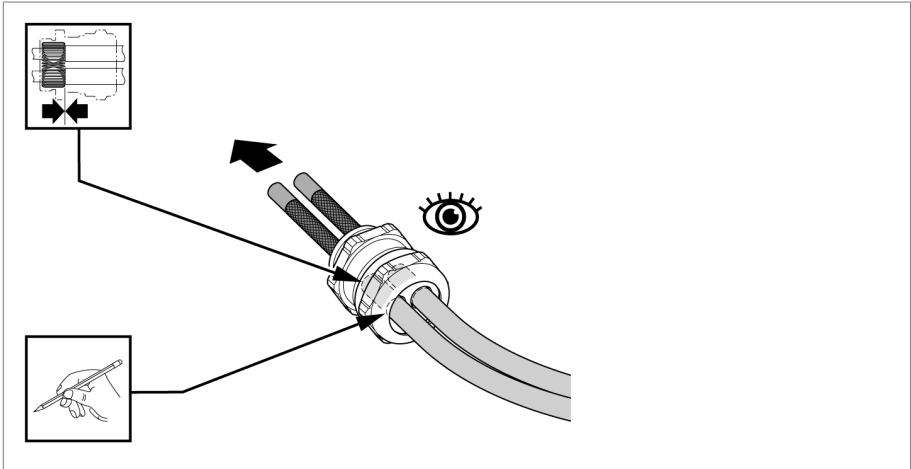

Figure 37: Marking the cables

4. Pull the cables back out to a length of 10 mm from the marking.

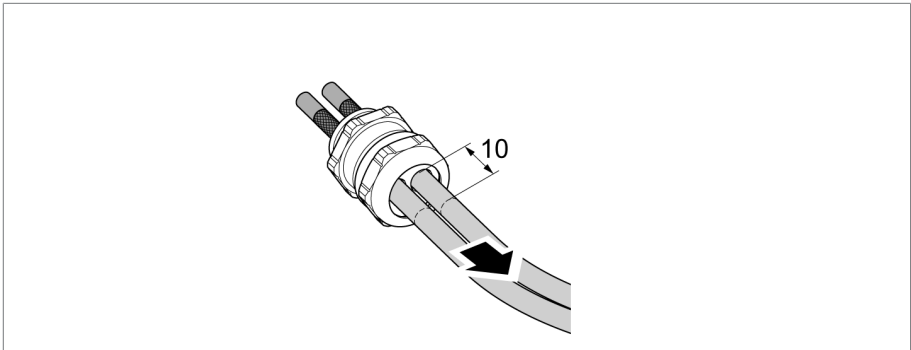

Figure 38: Pulling the cables out

5. Attach the cable gland to the device housing (wrench size 30).

6. Tighten the pressure screw on the cable gland (wrench size 30) with approx. 15 Nm.

Cable example (suitable for winding temperature indicators up to 50 °C ambient temperature and for oil temperature indicators up to 65 °C ambient temperature):

6 Installation and commissioning

Unitronic Robust C (TP) 3 x 2 x 0.5 from Lapp

- Shielded; 3x twisted pair (TP); 0.5 mm²
 - 1 TP used for 24 VDC
 - 1 TP used for Modbus A and B
 - 1 TP used for Modbus_Common_GND
- External diameter 8.7 mm

Also refer to

- 📖 Connecting cable glands/NPT adapters [► 74]

6.4.4.5 1/2" 14NPT adapter

1. Remove the locking cap.

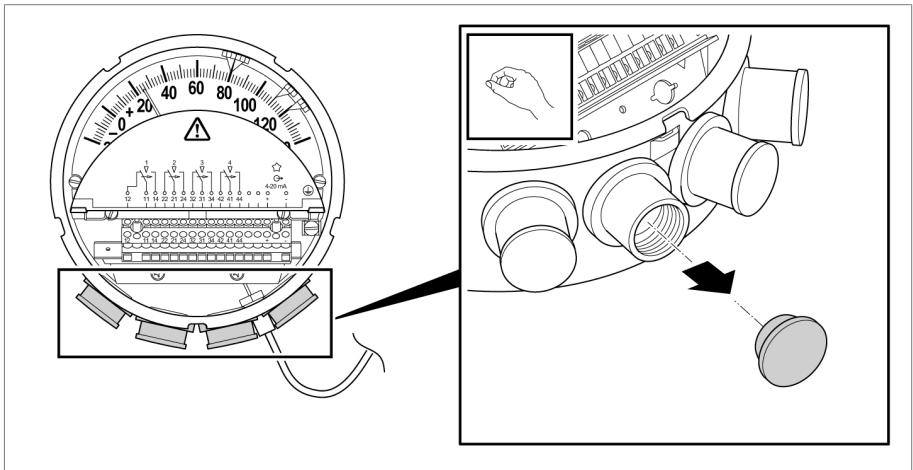

Figure 39: Removing the locking cap

2. Screw a cable conduit or cable tube with 1/2" 14NPT external thread into the adapter correctly and tightly. Feed through a sufficient length of cable.

Also refer to

- 📖 Connecting cable glands/NPT adapters [► 74]

6 Installation and commissioning

6.4.4.6 3/4" 14NPT adapter

1. Remove the locking cap.

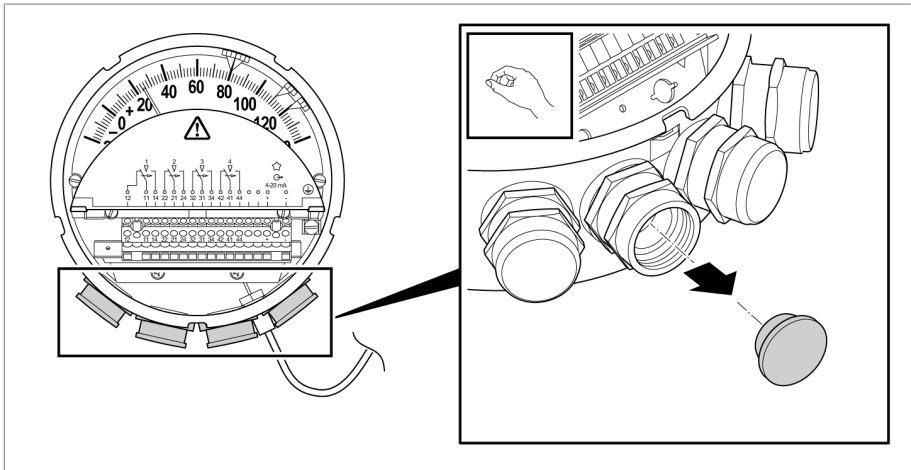

Figure 40: Removing the locking cap

2. Hold the adapter with an open-end wrench.

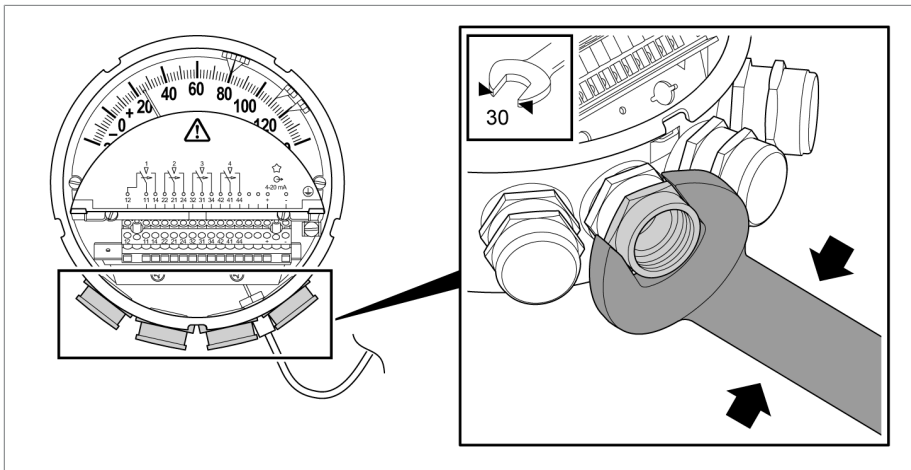

Figure 41: Holding the adapter

3. Screw a cable conduit or cable tube with 3/4" 14NPT external thread into the adapter correctly and tightly. Feed through a sufficient length of cable.

Also refer to

▣ Connecting cable glands/NPT adapters [► 74]

6 Installation and commissioning

6.4.5 Connecting the protective conductor

⚠ DANGER



Electric shock

Risk of fatal injury due to lack of protective conductor connection.

- ▶ Always connect the protective conductor connection before connecting any potentially dangerous circuits.

6.4.5.1 Connecting the protective conductor for oil temperature indicator without plug and without interface

This section only applies for the basic MT-ST160SK Standard version without the RM option and without interface (not for type TT or type TTM).

To connect the protective conductor to the pointer thermometer, proceed as follows:

- ▶ Equip the protective conductor (PE) with a forked cable shoe or ferrule and secure it to the protective conductor screw of the pointer thermometer.

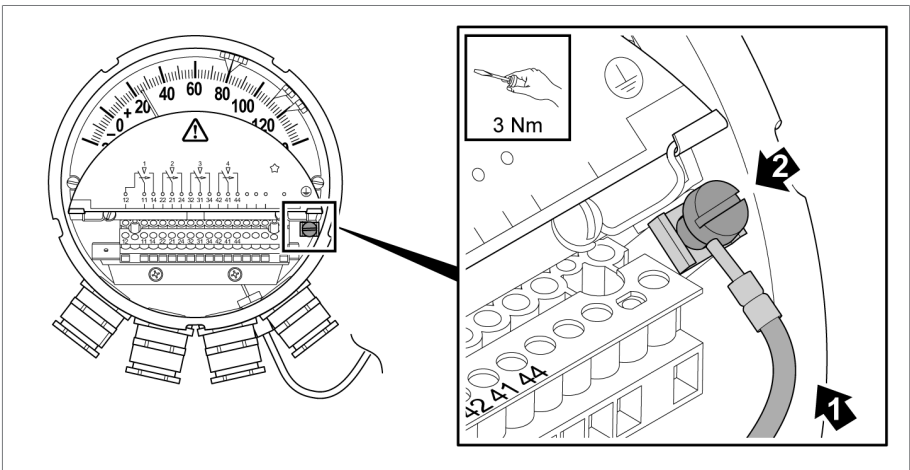

Figure 42: Connecting the protective conductor to the pointer thermometer

6 Installation and commissioning

6.4.5.2 Connecting the protective conductor for other device versions without plug

This section applies for all oil temperature indicators with interface (type TT and type TTM) and without plug connection (without RM option).

This section also applies for all winding temperature indicators without plug connection (without RM option), regardless of whether they are with or without interface.

To connect the protective conductor to the pointer thermometer, proceed as follows:

- ▶ Equip the protective conductor (PE) with a forked cable shoe or ferrule and secure it using the protective conductor screw of the pointer thermometer.

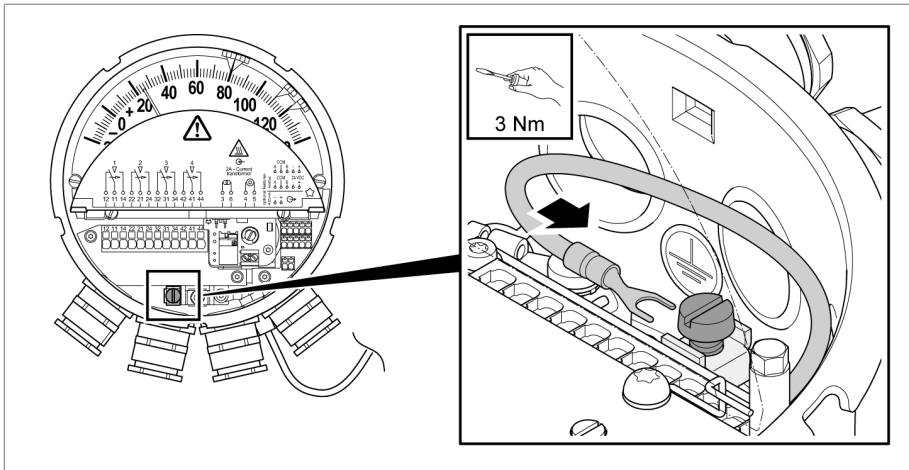

Figure 43: Connecting the protective conductor

6.4.5.3 Connecting the protective conductor for devices with plug (Compact RM)

This section applies for all devices with the option RM: MT-ST160SK/.../RM and MT-ST160W(R)/.../RM.



The PE connection must be corrosion-resistant.

6 Installation and commissioning

For pointer thermometer versions with plug, the protective conductor connection must be established as follows:

- Connect the pointer thermometer to the grounding point of the transformer using the protective conductor cable via the PE connecting bolt attached to the housing. Check the electrical contact of the protective conductor connection.

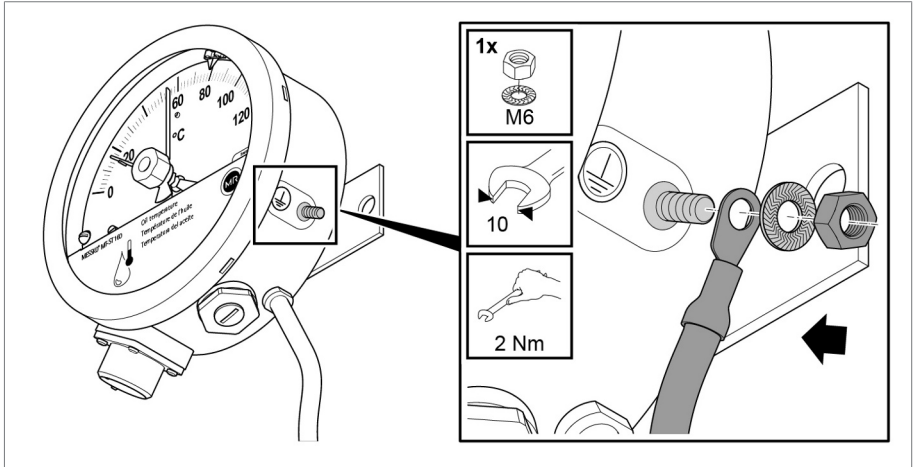

Figure 44: Connecting the protective conductor to the pointer thermometer

6 Installation and commissioning

6.4.6 Connecting the interfaces (optional)

NOTICE

Damage to the device!

Applying an incorrect test voltage to the terminals for the 4...20 mA analog outputs (types TT, TTM) or to the terminals for Modbus and the supply voltage (type TTM) can cause damage to the device.

- ▶ Perform the dielectric test (terminals to ground) with a maximum of 500 VDC.



If the number of cable glands is not sufficient, multiple glands can be used, for example to route the supply cable as well as an incoming and an outgoing cable for Modbus into the device through one cable gland at the same time. EMC double cable glands [▶ Section 6.4.4.4, Page 54] can be ordered as accessories (material no. 10173481).



Limited space in the device can make the connection more difficult. Connect the data lines before the micro-switches. Route the cables for the micro-switches through the left-hand cable gland.

Preparation

1. Strip the cable to a suitable length.
2. Strip a length of 8 mm of insulation from the wires.

6 Installation and commissioning

3. Use ferrules for flexible lines (with a collar of max. 0.75 mm²).

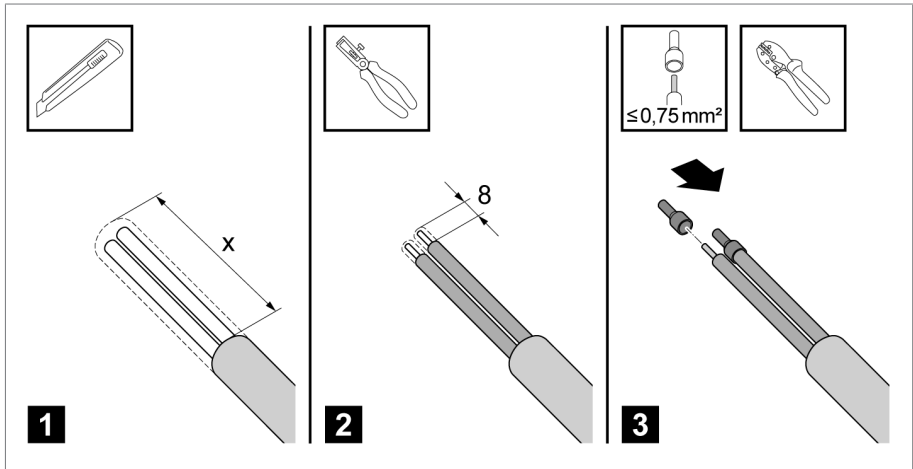

Figure 45: Cable preparation for interfaces



You will need an actuating tool if wires have to be released from the Push-in terminals used.

An actuating tool is not absolutely necessary for connecting the wires. When using wires with sufficient buckling resistance, direct plugging is possible without an actuating tool.

6.4.6.1 Passive 4...20 mA analog output (type TT) connection

The pointer thermometer is equipped with a passive analog output that issues the temperature value as an electrical 4...20 mA signal.

Connecting the passive analog output in accordance with the connection diagram

1. Press in the white actuator using the actuating tool (width 2.5 mm).
2. Connect the wires to the terminals "4...20 mA (+/-)". Do so by pushing the wires through the opening up to the stop.

6 Installation and commissioning

3. Release the white actuator.

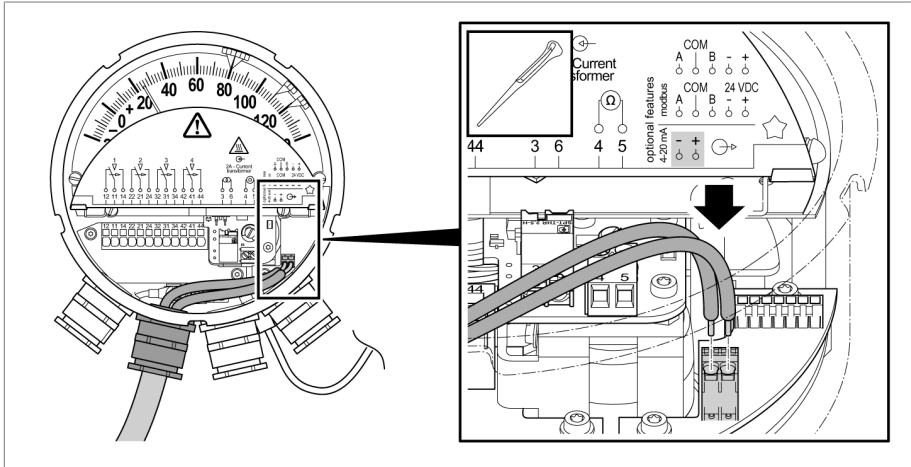

Figure 46: Connecting the analog output

4. Connect an evaluation unit with driving output (18...30 VDC) or, if necessary, an additional power supply (24 VDC).

6.4.6.2 Active 4...20 mA analog output (type TTM) connection

The pointer thermometer is equipped with an active analog output that issues the temperature value as an electrical 4...20 mA signal.

Connecting the 24 VDC power supply in accordance with the connection diagram

1. Press in the white actuator using the actuating tool (width 2.5 mm).
2. Connect the wires to the terminals "24 VDC (+/-)". Do so by pushing the wires through the opening up to the stop.

6 Installation and commissioning

3. Release the actuator.

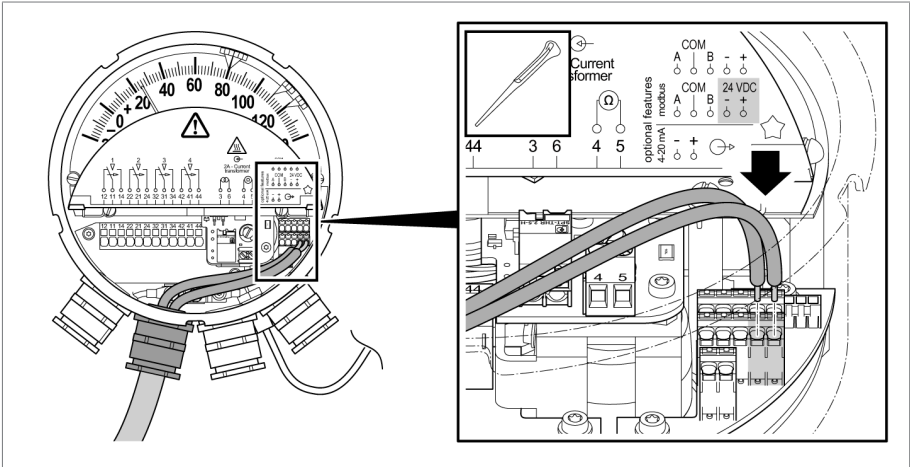

Figure 47: Connecting the supply voltage

Connecting the 4...20 mA analog output in accordance with the connection diagram

1. Use the same method to attach the wires for the analog output to the terminals "4...20 mA (+/-)". Do so by pushing the wires through the opening up to the stop.

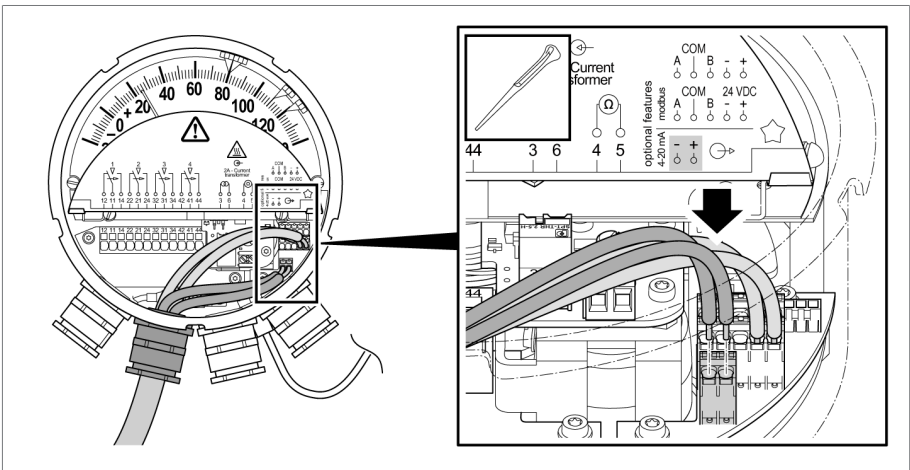

Figure 48: Connecting the analog output

2. Connect an evaluation unit without a driving input.

6 Installation and commissioning

6.4.6.3 Modbus RTU (type TTM) connection

The pointer thermometer is equipped with a Modbus RTU (RS-485) interface that digitally transmits the temperature value. The interface has a half-duplex design.

Connecting the 24 VDC power supply in accordance with the connection diagram

1. Press in the white actuator using the actuating tool (width 2.5 mm).
2. Connect the wires to the terminals "24 VDC (+/-)". Do so by pushing the wires through the opening up to the stop.
3. Release the actuator.

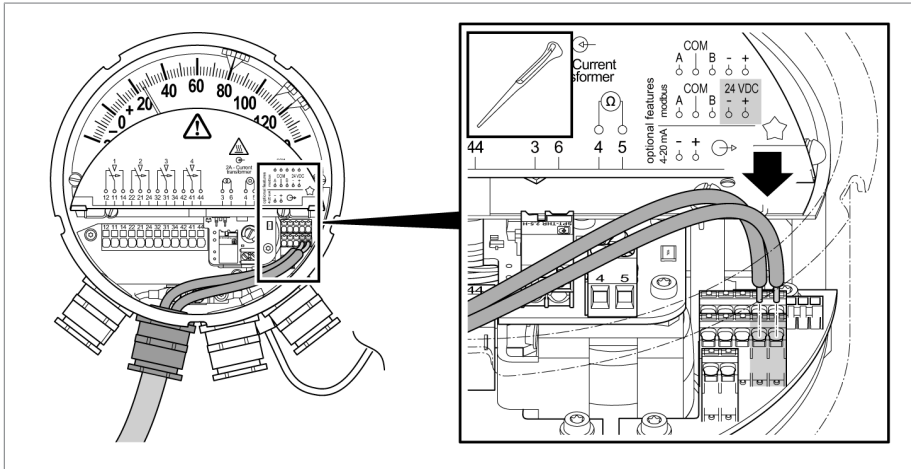

Figure 49: Connecting the supply voltage

6 Installation and commissioning

Connecting the Modbus RTU in accordance with the connection diagram

- Use the same method to attach the wires for the Modbus RTU to the terminals "A", "COM" and "B". Do so by pushing the wires through the opening up to the stop.

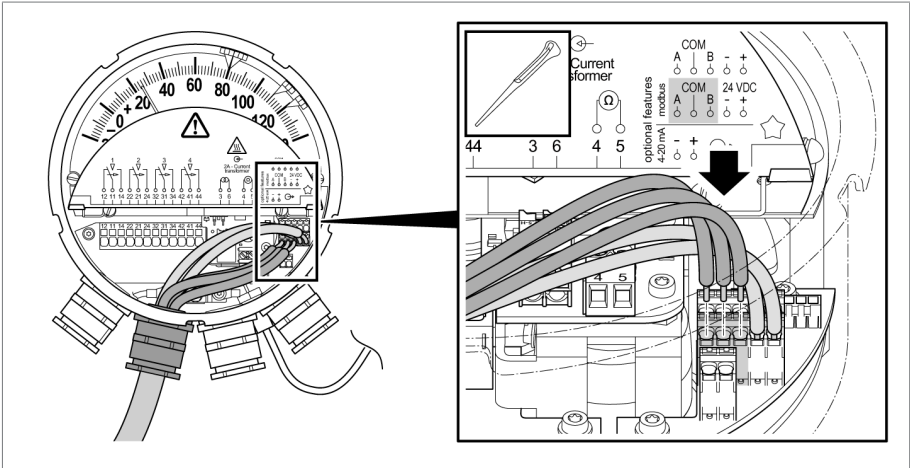

Figure 50: Connecting Modbus



The circuit board provides the possibility to loop through the RS-485 connection to the next device (daisy-chain) via the second terminal strip.

If the device is the only bus device or the last bus device, insert a terminating resistor (120 Ω , 0.5 W) into the second terminal strip between "A" and "B".

6.4.7 Connecting the micro-switches

⚠ WARNING



Electric shock

The micro-switches may be connected either to only extra-low-voltage circuits or to only low-voltage circuits. Mixed voltages are not permitted.

6 Installation and commissioning

⚠ WARNING



Electric shock

If a wire comes loose from a terminal, it is important to prevent dangerous voltage and extra-low voltage from meeting.

- ▶ Secure wire bundles with a dangerous contact voltage with a cable tie.
- ▶ Also secure wire bundles with extra-low voltage with a cable tie.

6.4.7.1 Connection for micro-switches for oil temperature indicator without plug and without interface

This section only applies for the basic MT-ST160SK Standard version without the RM option and without interface (not for type TT or type TTM).

To connect the micro-switches, proceed as follows:

- ▶ Connect the wires to the terminal strip in accordance with the connection diagram.

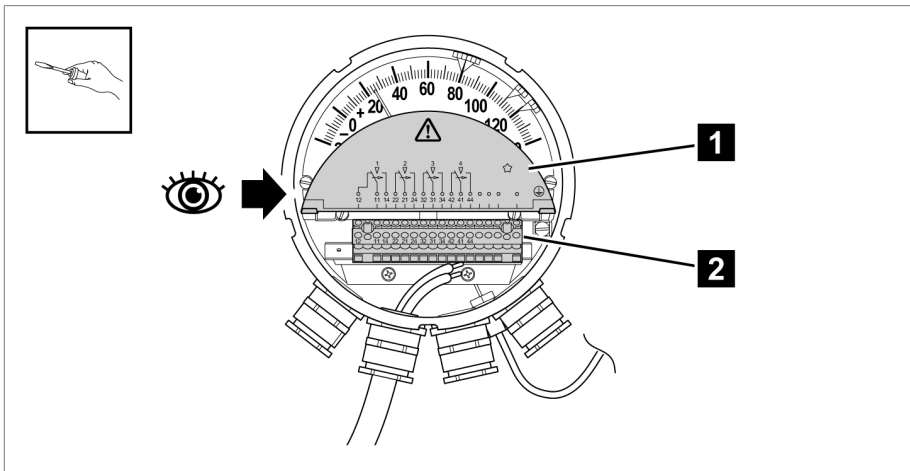

Figure 51: Connecting the micro-switches

1 Connection diagram

2 Terminal strip

6.4.7.2 Connection for micro-switches for other device versions without plug

This section applies for all oil temperature indicators with interface (type TT and type TTM) and without plug connection (without RM option).

6 Installation and commissioning

This section also applies for all winding temperature indicators without plug connection (without RM option), regardless of whether they are with or without interface.



Limited space in the device can make the connection more difficult. Connect the data lines before the micro-switches. Route the cables for the micro-switches through the left-hand cable gland.

Prepare the following before connecting the micro-switch cable:

1. Strip the cable to a suitable length.
2. Strip a length of 10–12 mm of insulation from the wires.
3. Use ferrules if necessary (max. 2.5 mm²)



You will need an actuating tool if wires have to be released from the Push-in terminals used.

An actuating tool is not absolutely necessary for connecting the wires. When using wires with sufficient buckling resistance, direct plugging is possible without an actuating tool.

Connect the wires to the terminal strip in accordance with the connection diagram. To do so:

1. Insert the actuator tool (width 2.5 mm) into the opening behind the respective connection.
2. Route the cable through the front opening until the stop.

6 Installation and commissioning

3. Remove the actuator tool.

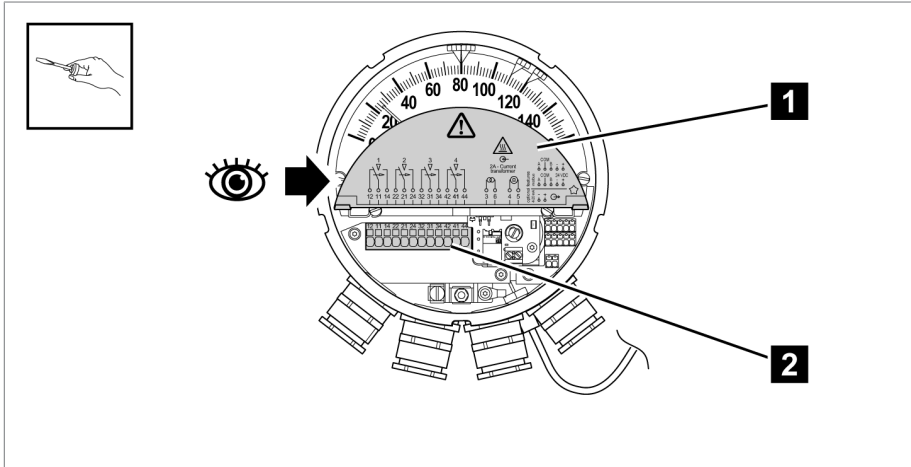

Figure 52: Micro-switch board connection

1 Connection diagram

2 Terminal strip

6.4.7.3 Connection for micro-switches via M plug (Compact RM)



Devices with a plug connection may be set up with either only extra-low-voltage circuits or only low-voltage circuits using the device plug.

6 Installation and commissioning

In order to connect the M plug, proceed as follows:

1. **NOTICE!** Damage to cables and conductors! When installing the M plug connector on the M plug, the cable can twist. Twisting can cause cable breaks. Push the plug connector onto the device plug, hold the cable and turn the threaded cap clockwise to the stop. The cable may not rotate while this is happening.

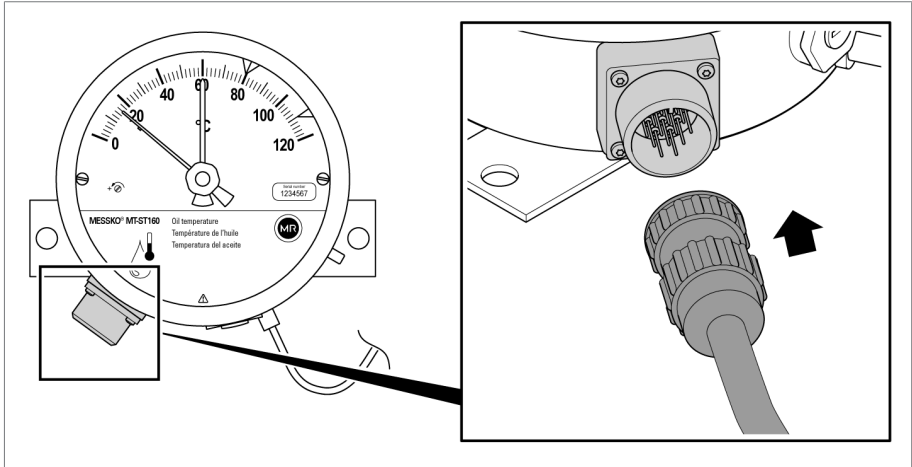

Figure 53: Connecting the M plug

2. **NOTICE!** Interruption of the plug connection! If the connection cable is not routed and secured sufficiently, the plug connector can be ripped out of the housing plug. Secure the connection cable sufficiently and make sure that the plug connector is not under tension.

6 Installation and commissioning

3. Connect the wires at the free end of the connection cable in the control cabinet in accordance with the supplied connection diagram.

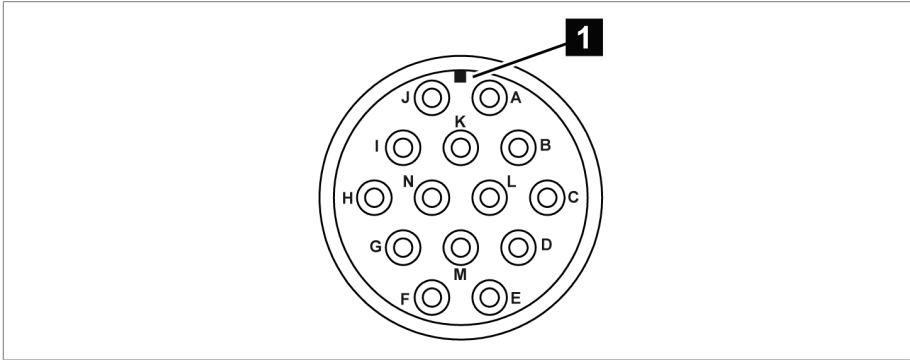

Figure 54: Connection assignment, view of installed M plug

1 Coding contour

A Black

B Red

C Blue

D Orange

E Yellow

F Brown

G Red/black

H Blue/black

I Orange/black

J Yellow/black

K Brown/black

L Black/red

M -

N -

6.4.7.4 Connection for micro-switches via ANSI plug (Compact RM)



Devices with a plug connection may be set up with either only extra-low-voltage circuits or only low-voltage circuits using the device plug.

6 Installation and commissioning

To connect the micro-switches, proceed as follows:

1. **NOTICE!** Damage to cables and conductors! When installing the ANSI plug connector on the ANSI plug, the cable can twist. Twisting can cause cable breaks. Push the plug connector onto the device plug, hold the cable and turn the threaded cap clockwise to the stop. The cable may not rotate while this is happening.

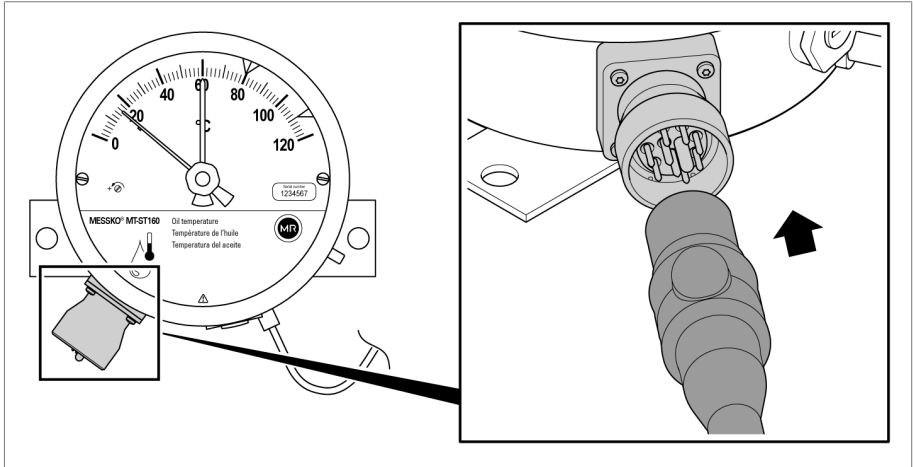

Figure 55: Connecting the ANSI plug

2. **NOTICE!** Interruption of the plug connection! If the connection cable is not routed and secured sufficiently, the plug connector can be ripped out of the housing plug. Secure the connection cable sufficiently and make sure that the plug connector is not under tension.

6 Installation and commissioning

3. Connect the wires at the free end of the connection cable in the control cabinet in accordance with the supplied connection diagram.

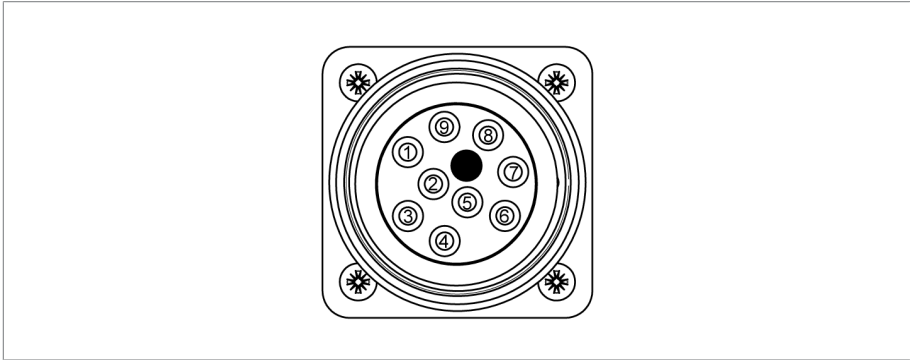

Figure 56: Connection assignment, view of installed ANSI connector

1 Black	2 Red
3 Blue	4 Orange
5 Yellow	6 Brown
7 Red/black	8 Blue/black
9 Orange/black	

6.4.8 Connecting cable glands/NPT adapters

NOTICE

Damage to the device!

The supplied locking screws are intended to protect the device from moisture and the like during transport. If you do not use any locking screws or if you use the wrong ones, the IP55 degree of protection and the necessary flame protection cannot be guaranteed.

Metal locking screws are available as accessories.

- ▶ Seal unneeded cable glands/NPT adapters with suitable locking screws and gaskets to ensure the IP55 degree of protection and the flame protection.
- ▶ Screw the locking screw into the unused connection.

6.5 Checking micro-switches

NOTICE

Damage to the device!

If you move the micro-switches on the colored indicator points, they can bend or break.

- ▶ Only move micro-switches on the retaining bridges of the indicator points.

NOTICE

Damage to the device!

Turning the pointer counter-clockwise can damage the device.

- ▶ Only turn the pointer clockwise.

6.5.1 Micro-switch to the right of the pointer

If the micro-switch is to the right of the pointer, proceed as follows:

1. **NOTICE!** Damage to the device! If the pointer jumps back to the starting position, the micro-switches can be damaged. Turn the pointer clockwise past the micro-switches by hand and do not let go. Check the function here and, if necessary, connect a continuity tester to the terminal strip to do so.

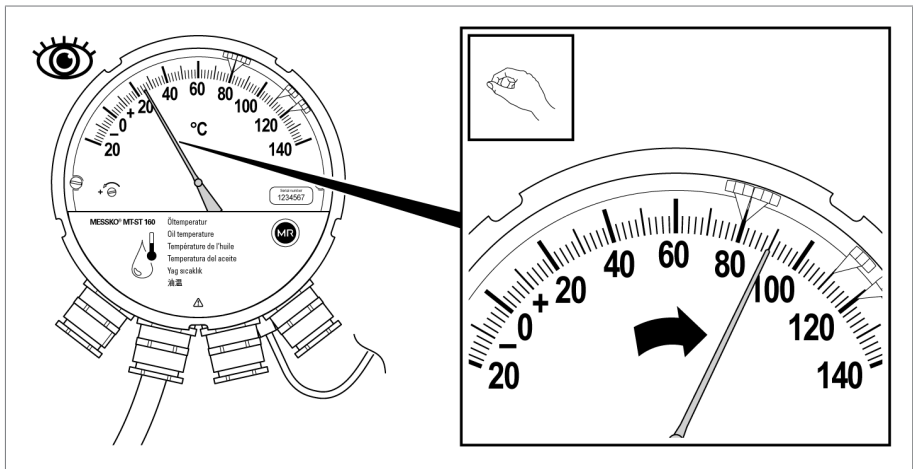

Figure 57: Moving the pointer past the micro-switches

6 Installation and commissioning

2. Slowly return the pointer to its starting position.

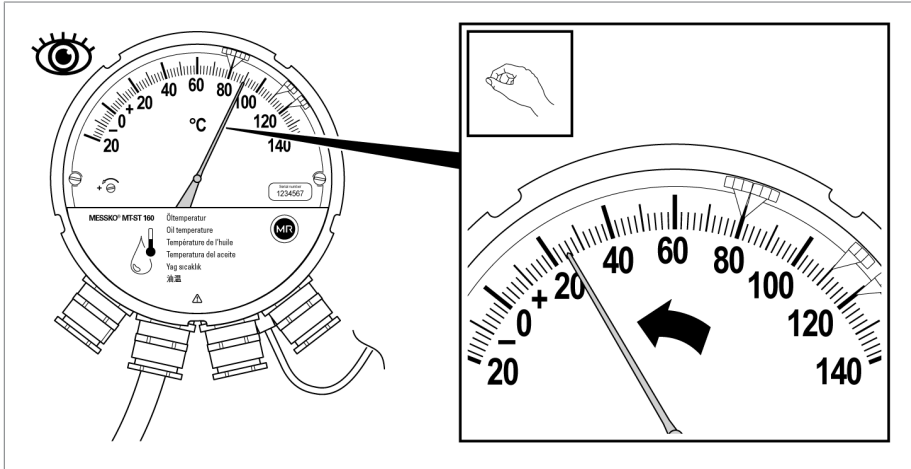

Figure 58: Returning the micro-switches

⇒ A return spring pulls the pointer back to its exact starting position.

6.5.2 Micro-switch to the left of the pointer

If the micro-switch is to the left of the pointer, proceed as follows:

1. Move the micro-switches clockwise past the pointer individually and in succession and check the function. If necessary, connect a continuity tester to the terminal strip to do so.

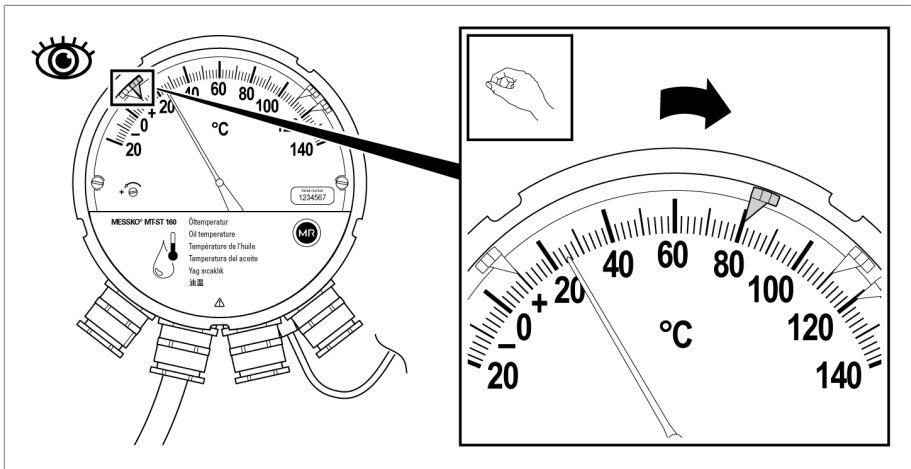

Figure 59: Moving the micro-switches past the pointer

6 Installation and commissioning

2. Set the micro-switches back to their original value.

6 Installation and commissioning

6.6 Setting temperature gradients (winding temperature)

Since the temperature sensor is located in a thermometer pocket instead of directly in the winding, the temperature difference between the winding and the insulating fluid must be taken into account. The temperature difference at nominal load is called the temperature gradient. This is specified by the transformer manufacturer. The temperature difference is reproduced in the thermometer by a heating resistor that is supplied with the secondary transformer current of the transformer.



Setting the temperature gradient is necessary for thermometers to display the winding temperature. Perform this setting before commissioning the transformer and before connecting the current transformer.

The pointer thermometer is set at the factory as follows:

Parameter	Setting
Nominal secondary transformer current	2 A
Temperature gradient	17 K
Nominal heating current for MT-ST160W	0.95 A
Nominal heating resistance for MT-ST160WR	4.5 Ω

Table 8: Factory settings

If the temperature gradient of the transformer deviates from this default setting, you must adjust the temperature gradient of the thermometer. Depending on the device version, there are two different processes to do this:

- MT-ST160W(/RM): Gradient setting by heating current
 - You need a constant current source and a voltmeter.
- MT-ST160WR(/RM): Gradient setting by resistance value
 - You need an ohmmeter and, for a second (optional) calibration before commissioning, a calibration bath and a source of current.

6 Installation and commissioning

6.6.1 Gradient setting by heating current (W)

For the MT-ST160W and MT-ST160W/RM device versions, set the temperature gradient by adjusting the heating current.

You can measure the heating current indirectly via the voltage drop on the internal 0.1Ω resistor. Using the equation $I = U/R$, with $R = 0.1 \Omega$, the heating current I_H is equal to the measured voltage V divided by the resistance value 0.1Ω . The heating current can be adjusted by setting the potentiometer P .

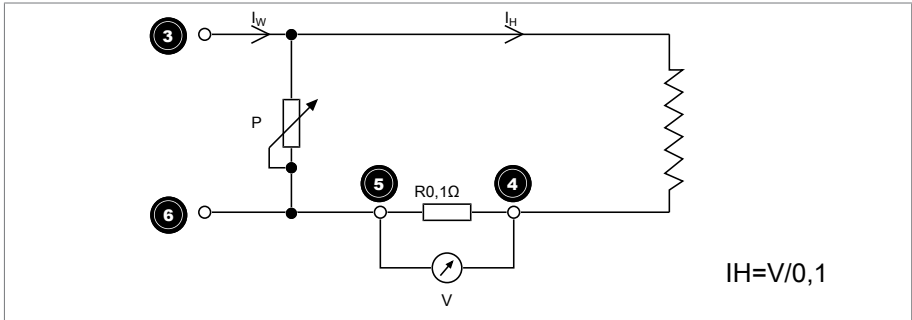

Figure 60: Circuit

I_W Secondary transformer current

I_H Heating current

P Potentiometer

V Voltage measurement

6 Installation and commissioning

Setting curve for the heating current

The heating current to be set is determined depending on the required temperature gradient gr from the following setting curve:

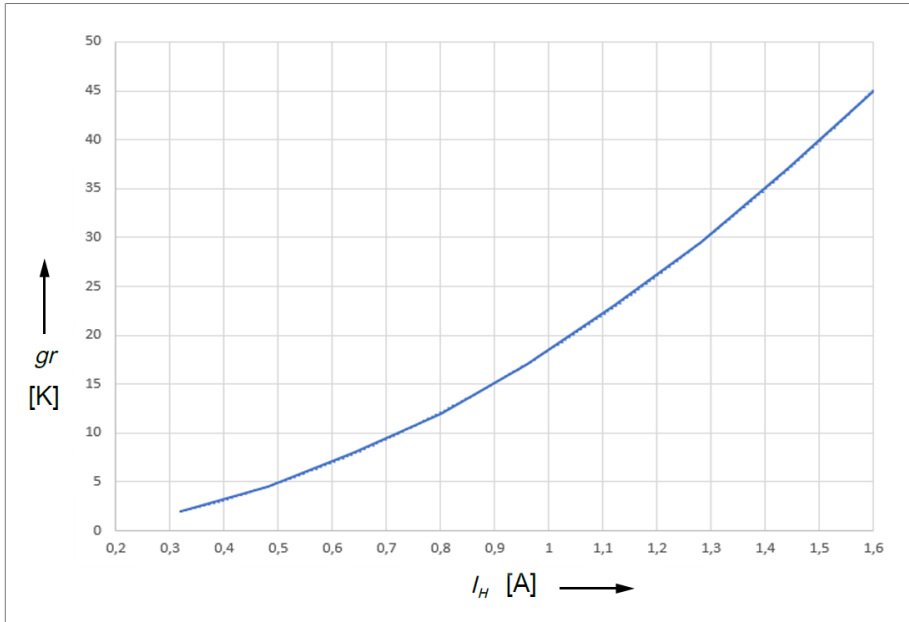

Figure 61: Setting curve

gr Temperature gradient

I_H Heating current

Example:



Temperature read: 30 °C

Required temperature gradient: 20 K

Required display temperature: 30 °C + 20 K = 50 °C

Nominal secondary transformer current: 2.0 A

Heating current from setting curve: 1.05 A

6 Installation and commissioning

Setting temperature gradients

- ✓ Make sure that the temperature on the temperature sensor remains constant during the setting process.
 - ✓ Open the cover plate.
1. Write down the temperature currently displayed (e.g. 30 °C).
 2. Connect a constant current source to terminals 3 and 6.

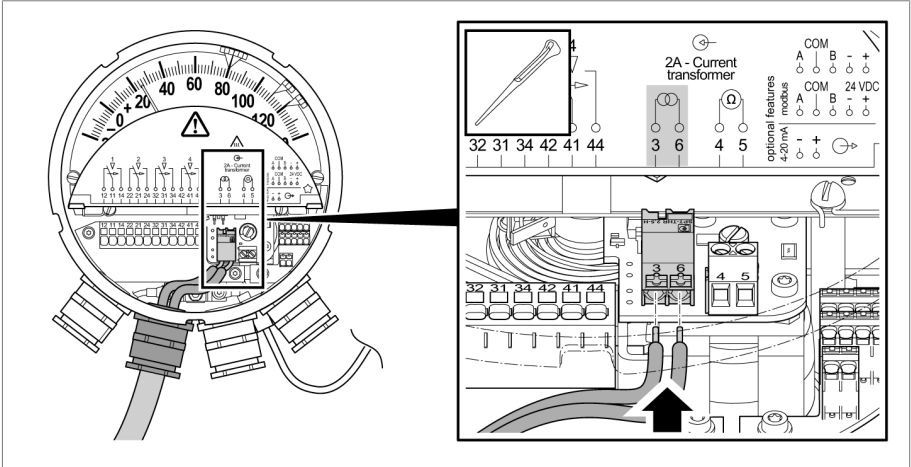

Figure 62: Current source connection

3. Set the nominal secondary transformer current I_w (e.g. 2 A) on the current source.

Determining the heating current

- ✓ The value of the temperature gradient is specified by the transformer manufacturer (e.g. $gr = 20 \text{ K}$).
1. Read the associated value for the heating current from the setting curve (desired value, 1.05 A in this example).
 2. Determine the voltage on terminals 4 and 5 using a high-resistance voltmeter.
 - ⇒ Value of the heating current: $I_H = V/0.1$.

6 Installation and commissioning

- Use the adjusting screw of the potentiometer to make an adjustment until the numerical value of the measured voltage matches the desired value of the heating current (1.05 A in this example). Turning the adjusting screw to the right causes the heating current to increase, and turning it to the left causes it to decrease.

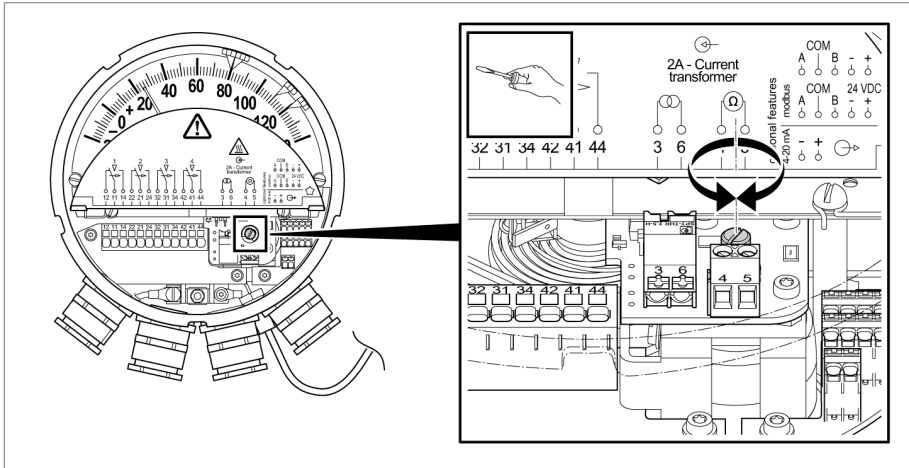

Figure 63: Potentiometer setting

- Check the required temperature increase: In this example, the temperature of the temperature sensor (30 °C) should be increased by the temperature gradient of 20 K, thus resulting in 50 °C being displayed. Take the heating and cooling time of approx. 15 minutes into account.
 - ⇒ If the desired temperature value is not reached after approx. 30 minutes, adjust the temperature gradient on the potentiometer again.
- After setting the temperature gradient, remove the current source and voltmeter.

6 Installation and commissioning

6.6.2 Gradient setting by resistance value (WR)

For the MT-ST160WR and MT-ST160WR/RM device versions, set the temperature gradient by adapting the resistance value.

The resistance of the heating circuit is measured directly at terminals **4** and **5** with an ohmmeter. This resistance can be adjusted by setting the potentiometer P.

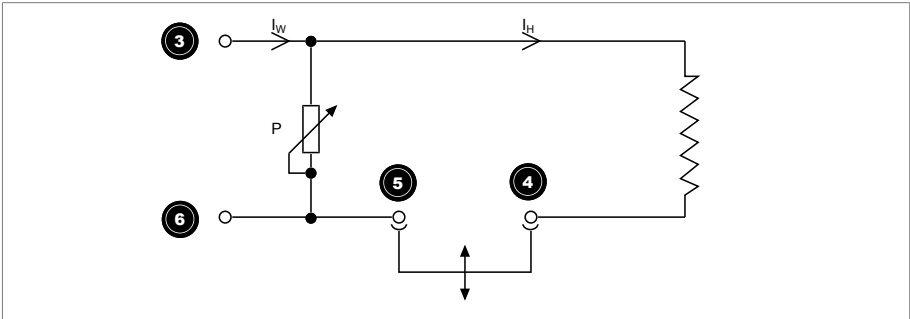

Figure 64: Circuit

I_W Secondary transformer current

I_H Heating current

P Potentiometer



The setting accuracy of the resistance value depends on the quality and measurement deviation of the measuring device used to measure the resistance value.

6 Installation and commissioning

Setting curve

The resistance value to be set depends on the nominal secondary transformer current and the temperature gradient of the transformer and results from the following setting curves:

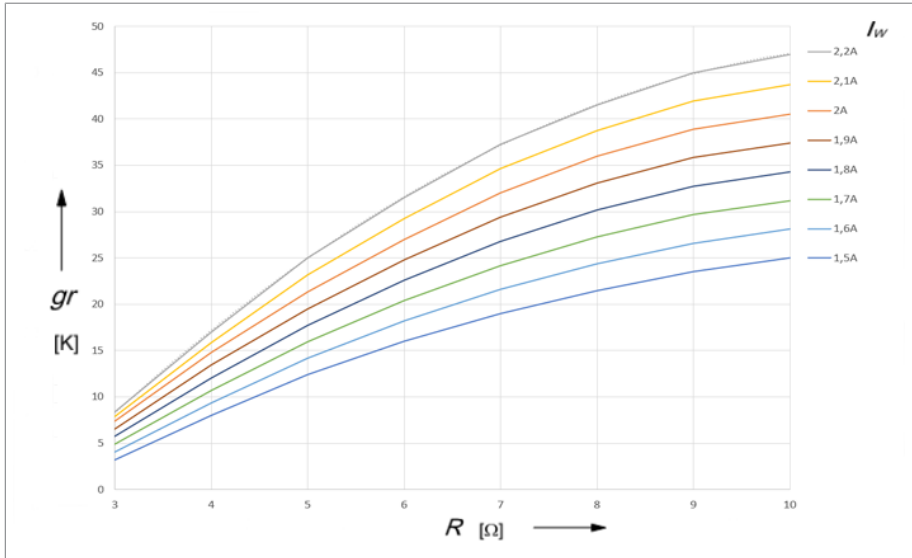

Figure 65: Resistance setting curve

gr Temperature gradient

R Resistance of the heating circuit

I_w Nominal secondary transformer current

Example:



Nominal secondary transformer current: 1.9 A

Required gradient: 26 K

Resistance value from setting curve: 6.2 Ω

✓ Open the cover plate.

1. Determine the necessary resistance value from the setting curve (6.2 Ω in this example).

6 Installation and commissioning

2. Remove the bridge at terminals 4 and 5.

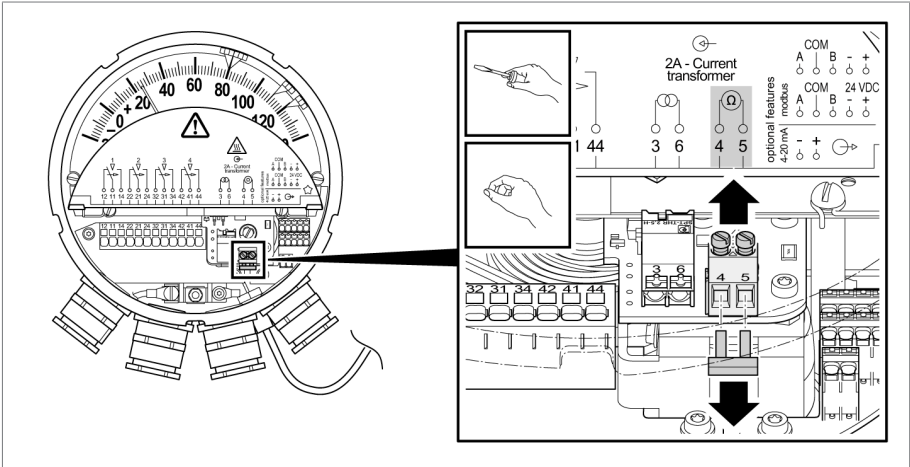

3. Connect an ohmmeter to terminals 3 and 6.

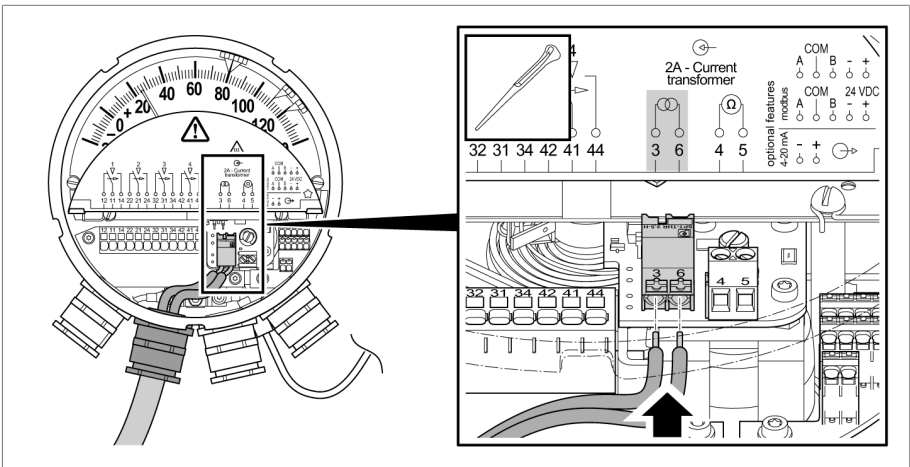

6 Installation and commissioning

- Set the required resistance value using the adjusting screw of the potentiometer. Turning the adjusting screw to the right causes the resistance value to increase, and turning it to the left causes it to decrease.

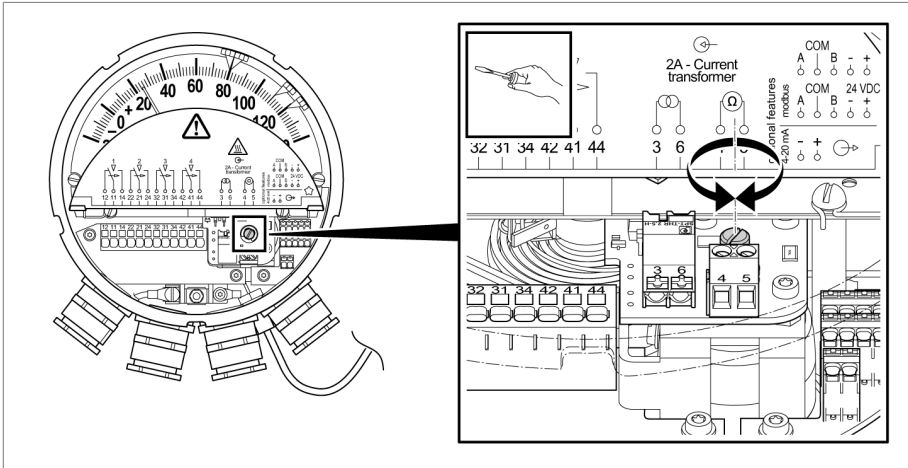

Figure 68: Potentiometer adjusting screw

- Remove the measuring device.
- Put the bridge back in terminals 4 and 5 and tighten the lock screws.



Since you are not working with the actual heating current during this setting process, we recommend a second calibration before commissioning.

Temperature gradient calibration before commissioning:

Example:



Displayed temperature without current source: 40 °C
Nominal secondary transformer current: 1.9 A
Required gradient: 26 K
Temperature display after gradient adjustment: 40 °C
+ 26 K = 66 °C

✓ The thermometer is mounted on the transformer.

- Note the temperature currently shown on the thermometer (e.g. 40 °C).

6 Installation and commissioning

2. If a constant temperature cannot be ensured, we recommend taking the temperature sensor out of the thermometer pocket and placing it in a thermometer calibration bath. Set the calibration bath to a temperature of 40 °C for this example.
3. Connect a current source to terminals 3 and 6 of the thermometer. Set the nominal secondary transformer current specified by the transformer manufacturer (e.g. 1.9 A) on the current source.
4. Wait until the temperature display stops changing (approx. 15 minutes).
5. Compare the temperature display to the previously calculated value (in this example, $40\text{ °C} + 26\text{ K} = 66\text{ °C}$).
6. If the required temperature value is not reached on the thermometer display, use the adjustment screw of the potentiometer to readjust (take the heating and cooling time of approx. 15 minutes into account).
7. If the displayed temperature remains at the required value constantly over a period of 30 minutes, the calibration is complete.
8. Reinstall the temperature sensor in the thermometer pocket.

6.7 Connecting the current transformer (winding temperature)

⚠ WARNING



Electric shock!

Dangerous high voltages may occur when a **current transformer** is operated with an open secondary circuit. This can lead to death, injuries and property damage.

- ▶ Make sure that there are no dangerous electrical voltages on the CT secondary circuit.
- ▶ Never operate a current transformer with an open secondary circuit; short-circuit the current transformer to prevent this.
- ▶ Ground the current transformer on one side.
- ▶ Observe the information in the current-transformer operating instructions.

6 Installation and commissioning

NOTICE

Damage to the device due to overload!

At a nominal secondary transformer current that is not 2 A, you must also use a universal multi-ballast transformer (e.g. MESSKO® MultiBallast-TX).

- ▶ Connect the universal multi-ballast transformer in accordance with the associated operating instructions.
- ▶ The device may be operated with an overload of up to 3 A input current for a maximum of 0.5 hours (in accordance with IEC 354).
- ▶ Open the cover plate.

Prepare the following before connecting the cable:

1. Strip the cable to a suitable length.
2. Strip the other to a length of 10 mm.
3. Use ferrules for flexible lines (maximum 2.5 mm²)

Connect wires to the terminal strip. To do so:

1. Press in the white actuator using the actuating tool (width 2.5 mm).
2. Route the cable through the opening until the stop.
3. Release the actuator.
4. Connect the wires for the current transformer (CT) to terminals 3 and 6.

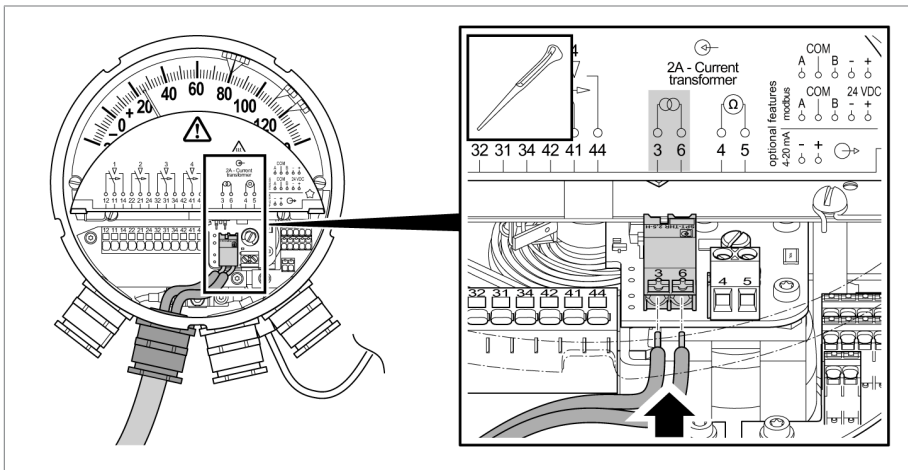

Figure 69: Current transformer connection

6 Installation and commissioning

6.8 Configuring Modbus (type TTM)

You can change the Modbus configuration settings if the factory settings are not suitable for your application. You need a configuration tool for this (e.g. the ASE2000 available on the market).

1. Connect the device individually to the RS485 BUS.
2. Change the Modbus address if necessary.
3. Adjust the parity and baud rate if necessary.

⇒ These will be adopted automatically five seconds after the new values are entered.

For more information (e.g. register content), see chapter Modbus RTU [► Section 11.4, Page 106] technical data.

Modbus baud rate setting

The transmission speed (baud rate) of the Modbus interface can be set as follows: 4800, 9600, 19200, 38400, 57600, 115200 baud.

Modbus baud rate	
Delivery state (factory setting)	19200 Bd
Maximum value	115200 Bd
Minimum value	4800 Bd

Setting the Modbus address

The following values are available for the Modbus address:

Modbus address	
Delivery state (factory setting) oil temperature indicator MT-ST160SK/... MT-ST160SK/.../RM	21
Delivery state (factory setting) winding temperature indicator MT-ST160W(R)/... MT-ST160W(R)/.../RM	22
Maximum value	247
Minimum value	1

6 Installation and commissioning



Issuing the same network address twice will lead to malfunctions.

Parity

For data transmission, the parity is determined as follows:

Parity	
Delivery state (factory setting)	Even
Optional	Odd / none

Ensure that the same Modbus settings are made in your SCADA system.

Also refer to:

Modbus RTU [► Section 11.4, Page 106]

6.9 Closing the cover plate

- Close the cover plate.

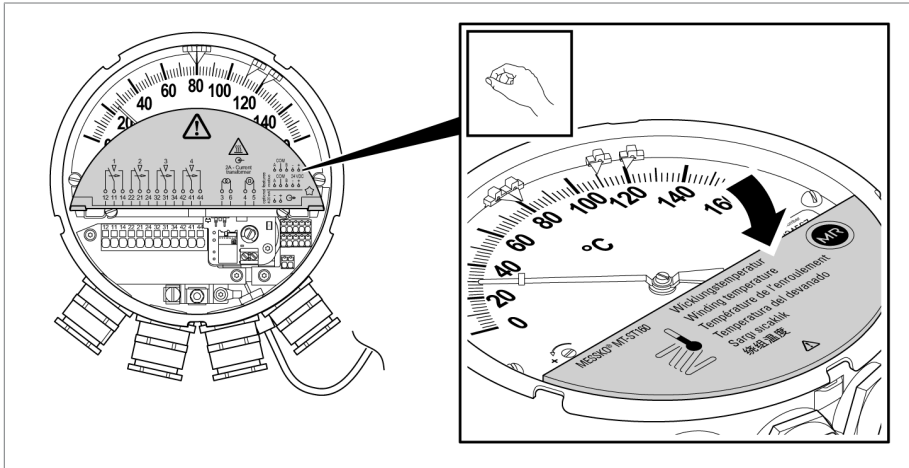

Figure 70: Closing the cover plate

6 Installation and commissioning

6.10 Positioning the bayonet seal ring

- ✓ Ensure that the drag hand is positioned to the right of the pointer.

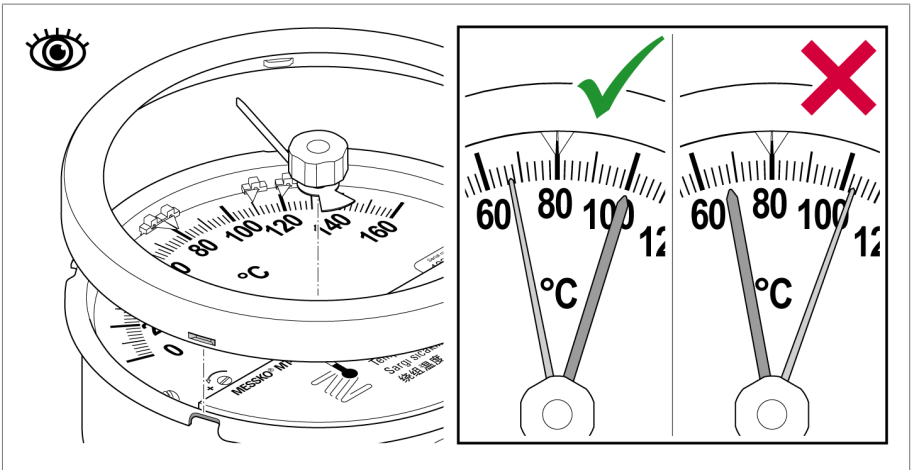

Figure 71: Position of the drag hand

- ▶ Reposition the bayonet seal ring with viewing glass on the pointer thermometer, press down firmly and turn 30...40° clockwise so that the viewing glass is pressed firmly into the rubber gasket all the way around.

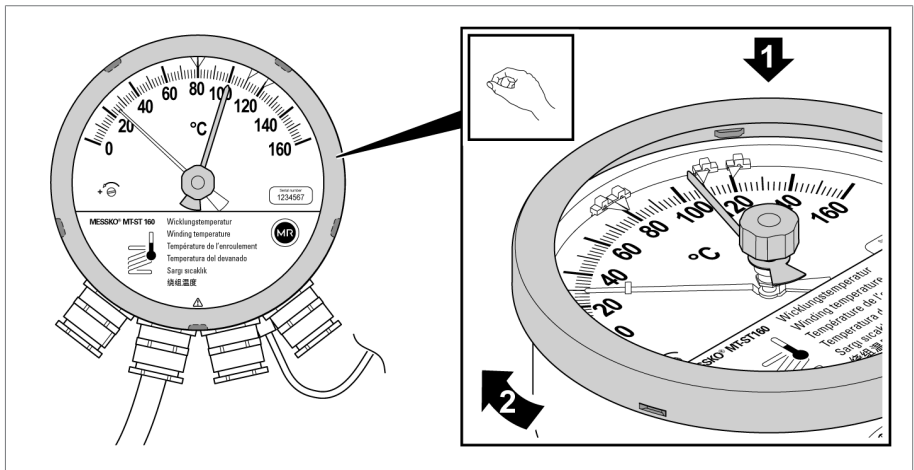

Figure 72: Positioning the bayonet seal ring

- ⇒ The pointer thermometer is ready for operation.

7 Operation

7.1 Resetting drag hands

The drag hand slides along with the pointer when measured temperature values increase and marks its maximum value. You can reset the drag hand as follows:

- ▶ Return the drag hand to the position of the thermometer pointer manually using the drag hand reset.
- ⇒ The drag hand and pointer are positioned one above the other.

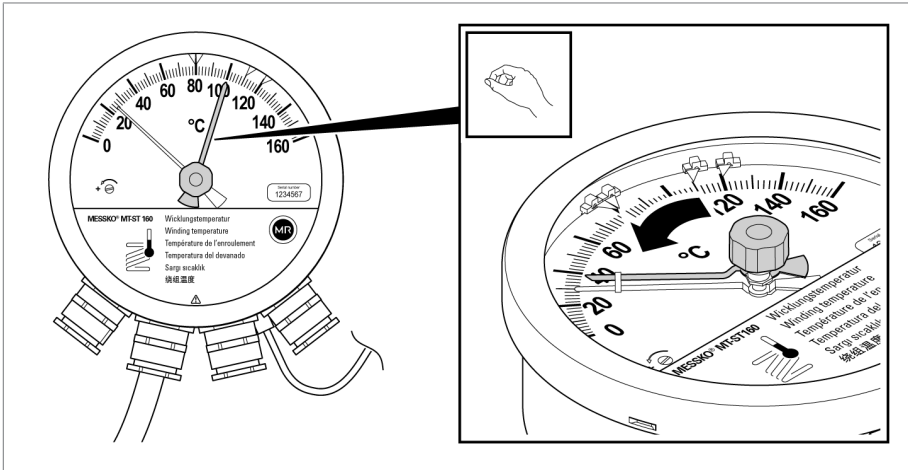

Figure 73: Resetting drag hands

8 Maintenance, inspection and care

Maintenance

The device is maintenance-free.

Inspection

Depending on the conditions of use of the device and the national regulations in the respective country of use, the transformer manufacturers can specify different inspection intervals.

- Observe the inspection intervals defined in CIGRE Publication No. 445 "Guide for Transformer Maintenance" or the inspection intervals specified by the transformer manufacturer.

During occasional visual inspections of the transformer, you can inspect and clean the device as follows:

1. Clean the housing of the device with a dry cloth.
2. Ensure that the ventilation is free of dirt and deposits.
3. Check the device for external damage and contamination.

In the event of questions or irregularities, contact the Technical Service department:

Maschinenfabrik Reinhausen GmbH

MR Service & Complaint
Falkensteinstrasse 8
93059 Regensburg
Germany

E-mail: service@reinhausen.com

9 Fault elimination

This chapter describes how to eliminate operating faults.

If a solution for a fault cannot be found, contact the manufacturer:

Maschinenfabrik Reinhausen GmbH

MR Service & Complaint
Falkensteinstrasse 8
93059 Regensburg
Germany

E-mail: service@reinhausen.com

E-mail: complaint@reinhausen.com

Please have the following data ready:

- Serial number
- Software version

Questionnaire for preparation

1. Has there previously been a problem with this device?
2. Have you previously contacted Maschinenfabrik Reinhausen GmbH about this issue? If yes, then who was the contact?
3. When did the error first occur? Is there a correlation with events such as thunderstorms, lightning surge testing in the transformer station, transformer disconnection/reconnection after short circuit or ground fault, etc.?
4. Is the error constant or sporadic? Is there a correlation with other events/conditions, such as extreme ambient temperatures?
5. Is there an error in the transmission of the 4...20 mA analog signal or in the Modbus transmission?
 - Are you using shielded lines?
 - Are you using a twisted pair line?
 - Is the cable shielding attached on both sides?
 - What is the cable length?
 - Which receiver do you use as a receiver?
 - 4...20 mA analog signal: What is the load resistance?
 - Modbus: Are there other devices on the Modbus?
 - Type TTM: Please tell us the value of the status register.

Checking the plausibility of the measured values

If the device is working but not reporting plausible values, check, document and compare the following:

- Measured value via 4...20 mA analog output
- Measured value via Modbus RTU interface
- Measured value via pointer on the scale
- Actual physical measured value (measured or estimated).

Calculating the target current of the 4...20 mA analog output

$$\blacktriangleright I_{\text{target}} = 4 \text{ mA} + 16 \text{ mA} * [(\text{current measured value scale} - \text{scale}_{\text{min}}) / (\text{scale}_{\text{max}} - \text{scale}_{\text{min}})]$$

Calculation example for the oil temperature indicator:

- Scale of -20...+140 °C; the indicator points to 60 °C
=> I_{target}
= 4 mA + 16 mA * [(60 °C - -20 °C)/(140 °C - -20 °C)]
= 4 mA + 16 mA * 0.5
= 12 mA

9.1 General malfunctions (type TT)

You are using a device with passive 4...20 mA analog output.

Characteristics/ details	Cause	Remedy
No function (4...20 mA)	Power supply not present	<ul style="list-style-type: none">▪ Check cables▪ Check power supply (18... 30 VDC)▪ Check 4...20 mA receiver (loop into multimeter)

Table 9: General faults

9 Fault elimination

9.2 General malfunctions (type TTM)

You are using a device with Modbus and active 4...20 mA analog output.

Characteristics/ details	Cause	Remedy
No function (4...20 mA)	Power supply not present	<ul style="list-style-type: none"> ▪ Check cables ▪ Check power supply (18... 30 VDC)
No function (Modbus)		<ul style="list-style-type: none"> ▪ Check 4...20 mA receiver (loop into multimeter) ▪ Check the Modbus receiver (supply, configuration)

Table 10: General faults

9.3 4...20 mA analog signal malfunctions (type TT and type TTM)

Characteristics/ details	Cause	Remedy
Loop current is approx. 3 mA	<ul style="list-style-type: none"> ▪ Device signals detected error 	<ul style="list-style-type: none"> ▪ At 3 mA: The self-diagnosis has detected an error that does not allow a reliable indication of the measurement. ▪ Type TTM: For possible causes/remedies, see section Self diagnosis/Data point DEVICE STATUS [► Section 9.5, Page 98]
The receiver does not measure any 4...20 mA loop current	<ul style="list-style-type: none"> ▪ 4...20 mA analog output was deactivated by holding register 4 ▪ Conductor break, open terminal point ▪ Short circuit ▪ Power supply not present ▪ Device defective 	<ul style="list-style-type: none"> ▪ Activate 4...20 mA analog output: switch holding register 4 from 0 to 1 ▪ Loop in multimeter and measure ▪ Check cables ▪ Check device supply (18... 30 VDC)

9 Fault elimination

Characteristics/ details	Cause	Remedy
The receiver measures a 20 mA loop current that is too low	<ul style="list-style-type: none"> ▪ A part of the current is running through a parallel path ▪ Load resistance too high ▪ Supply voltage too low ▪ Device defective 	<ul style="list-style-type: none"> ▪ Loop in multimeter and measure ▪ Check cables ▪ Check receiver (load resistance)
The receiver measures a 4...20 mA loop current that is too high	<ul style="list-style-type: none"> ▪ Device defective 	<ul style="list-style-type: none"> ▪ Loop in multimeter and measure

Table 11: 4...20 mA analog signal malfunctions

9.4 Modbus communication malfunctions (type TTM)

Characteristics/ details	Cause	Remedy
No communication possible (continuous)	Power supply not present	<ul style="list-style-type: none"> ▪ Check cables ▪ Check device supply (18... 30 VDC)
	<ul style="list-style-type: none"> ▪ RS485 lines A, B not connected or interrupted ▪ Short-circuit A, B ▪ Ground fault A and/or B ▪ RS485 connections swapped 	<p>Info: A = D0 = D+; B = D1 = D-</p> <ul style="list-style-type: none"> ▪ Check wiring ▪ Take a voltage measurement with a multimeter if necessary (A against B; A against Com; B against Com) ▪ Reconnect A, B if necessary
	<ul style="list-style-type: none"> ▪ Modbus address incorrect ▪ Modbus address assigned multiple times ▪ Baud rate ▪ Parity 	<p>Info: For factory settings, see chapter Modbus RTU [▶ Section 11.4, Page 106]</p> <ul style="list-style-type: none"> ▪ Check parameters (device and master) ▪ Change parameters if necessary; see chapter Configuring Modbus RTU [▶ Section 11.4, Page 106]
	<ul style="list-style-type: none"> ▪ Device defective 	-

9 Fault elimination

Characteristics/ details	Cause	Remedy
No communication possible (sporadic)	<ul style="list-style-type: none"> ▪ Modbus address assigned multiple times 	<ul style="list-style-type: none"> ▪ Check parameters (device and master) ▪ Change parameters if necessary; see chapter Configuring Modbus RTU [► Section 11.4, Page 106]
	<ul style="list-style-type: none"> ▪ Device defective 	-

Table 12: Modbus communication malfunction

9.5 Self-diagnostic / data point DEVICE STATUS (type TTM)

The device checks its own functionality cyclically (self-diagnostic).

In Modbus input register 0 (data type: UINT16), the device reports a corresponding status via status bits. Multiple bits can also be set at the same time.

Status "0" means that the device has not detected any error.

All errors are reversible.

Status bit value/characteristic/detail	Cause	Remedy
0: no error detected	-	-
1 and 2: Internal error	<ul style="list-style-type: none"> ▪ Device defective 	<ul style="list-style-type: none"> ▪ See Modbus communication malfunction ▪ Contact Maschinenfabrik Reinhausen GmbH.

9 Fault elimination

Status bit value/characteristic/detail	Cause	Remedy
4: Pointer out of measuring range: Pointer angle is 20 angular degrees smaller than the minimum angle (MIN mark on scale) or 20 angular degrees larger than the maximum angle (MAX mark)	<ul style="list-style-type: none"> ▪ Device defective ▪ Extremely low oil temperatures ▪ Extremely high oil temperature ▪ Extremely high CT current ▪ Extremely high gradient (with winding temperature indicator) 	<ul style="list-style-type: none"> ▪ Contact Maschinenfabrik Reinhausen GmbH. ▪ Are the oil temperatures/CT currents/gradients actually extremely low or high? Compare the reported temperature with the pointer position
8: 4...20 mA output deviation between target current and read-back current too high	<ul style="list-style-type: none"> ▪ Current loop is open (continuous load resistance) because you do not want to use the current loop at all ▪ Interruption of the 4...20 mA current loop ▪ Load resistance too high (possibly the conductor length and conductor cross-section not taken into consideration) ▪ Supply voltage too low ▪ Moisture in the device ▪ Extremely high ambient temperatures and/or CT currents (with winding temperature indicator) ▪ Device defective 	<ul style="list-style-type: none"> ▪ If you are not using the 4...20 mA analog output, we recommend deactivation via Modbus. Alternatively, you can connect a resistor (590 Ohm \pm20 %/0.5 W) as load resistance. If necessary, you can use a wire bridge. ▪ Check cables: loop open? Parallel paths? Current leaks? ▪ 4...20 mA cable: shielded, if possible with shielding on both sides; use twisted pair; do not run next to cables with interference ▪ Check for moisture/creep inside the device

Table 13: Status codes

10 Disposal

Observe the national disposal regulations in the country of use.

10.1 SVHC information in accordance with the REACH regulation

This product complies with the provisions of European Regulation 1907/2006/EC dated December 18, 2006 on the Registration, Evaluation, Authorization and Restriction of Chemicals (REACH).

The following components of the product contain > 0.1% [w/w] of the SVHC substance lead (CAS no. 7439-92-1):

- Aluminum alloy
- Brass alloy
- Standard parts with a low property class

11.1 Ambient conditions

Permissible ambient conditions	
Location of use	Indoors and outdoors, tropic-proof
Operating temperature ¹⁾	-40...+80 °C
Storage temperature ¹⁾	-50...+80 °C
Ambient air temperature ¹⁾	-50...+80 °C
Relative humidity	Fog-free up to 80%
Installation altitude ¹⁾	2,000 m above mean sea level
Degree of protection	IP55 in accordance with IEC 60529
Protection class	I
Overvoltage category	III
Contamination level	2 (within the device)

¹⁾ Extended ranges on request.

11.2 Technical data

	Pointer thermometer for oil temperature	Pointer thermometer for winding temperature
Compact measuring range	-20...+140 °C	0...+160 °C
Compact RM measuring range	0...+120 °C 0...+160 °C	0...+160 °C 0...+180 °C
Tolerance	±3 °C in accordance with DIN EN 13190 Class 1 and DIN 16196	

Basic materials	
Front ring and housing	Sheet steel, galvanized, coated in RAL 7033 in accordance with DIN EN ISO 12944-9 corrosion protection class C4H
Inspection window	Laminated safety glass
Temperature sensor	Bare brass
Retaining plate	Stainless steel

11 Technical data

Basic materials	
Capillary line	Copper capillary with protective jacket
Offshore optional	As per the requirements in accordance with DIN EN ISO 12944-9 with corrosion-protection class CX
Dimensions and weight	
Compact housing	Ø 173 mm [Ø 6.81"]; depth 98 mm [3.86"]
Compact RM housing	Ø 173 mm [Ø 6.81"]; depth 71 mm [2.80"]
Weight	Approx. 2.5 kg (with 6 m capillary line)
Passive 4...20 mA analog output (type TT)	
Feed-in voltage of the passive current loop	18...30 VDC unregulated, max. 10% residual ripple, protected against polarity reversal
Output signal	4...20 mA; passive; 2-conductor wiring <3.6 mA: Device diagnoses error
Max. load resistance	750 Ω at $U_b = 24$ VDC
Rated insulation voltage	500 VDC/1 min; terminals to ground
Repetition accuracy	≤ ±0.1% from the end value
Active 4...20 mA analog output (type TTM)	
Supply voltage	24 VDC unregulated, max. 10% residual ripple, protected against polarity reversal
Output signal	4...20 mA; active; 4-conductor wiring <3.6 mA: Device diagnoses error
Max. current consumption	40 mA
Max. load resistance	750 Ω at $U_b = 24$ VDC
Rated insulation voltage	500 VDC/1 min; terminals to ground
Repetition accuracy	≤ ±0.1% from the end value
RS485 interface for Modbus RTU (type TTM)	
Supply voltage	24 VDC unregulated, max. 10% residual ripple, protected against polarity reversal
Standard	EIA/TIA-485
Protocol	Modbus RTU

RS485 interface for Modbus RTU (type TTM)

Wiring	2-wire; half-duplex
Terminal designation	Polarity: A = D+; B = D-; COM=common ground Expected voltage between A and B in the idle state: >+200 mV
Rated insulation voltage	500 VDC/1 min; terminals to ground

11.3 Micro-switches

Micro-switch technical data

Quantity	1...6 adjustable micro-switches
Minimum switching distance	6% of the measuring range for standard switch arrangement; <1 K for narrowing
Switching hysteresis	Approx. 5 K (for decreasing temperature)
Protection	Miniature circuit breaker 6 A, type C
Rated insulation voltage in accordance with IEC 60076-22-1	2,500 VAC/1 min; terminals to ground 1,000 V AC/1 min; between open terminals
Lightning impulse withstand voltage in accordance with IEC 60076-22-1	4,000 V; terminals to ground 3,000 V; between open contacts
Contact material	Standard: silver alloy Optional: gold-plated contacts
Contact type	Change-over contact, normally open contact

11 Technical data

Utilization category in accordance with IEC 60947-5-1

Utilization category in accordance with IEC 60947-5-1	Typical application	Rating/nominal operation	
		U_N	I_N
AC-12 (50/60 Hz)	Regulation of resistive load and semi-conductor load resistance with disconnection via optocoupler	230 V	5 A
AC-15 (50/60 Hz)	Regulation of electromagnetic load resistance with AC voltage	230 V	0.26 A
		120 V	0.5 A
		24 V	2 A
DC-12	Regulation of resistive load and semi-conductor load resistance with disconnection via optocoupler	220 V	0.2 A
		120 V	0.4 A
		30 V	5 A
DC-13	Regulation of electromagnets with DC voltage	220 V	0.11 A
		120 V	0.21 A
		24 V	1.04 A

Switching capacity in accordance IEC 60076-22-1

Micro-switch version	U_N	Switching capacity in accordance IEC 60076-22-1
Standard switch	230 VAC	Making capacity: 250 VA, $\cos \varphi > 0.5$ Breaking capacity: 60 VA, $\cos \varphi > 0.5$
	24... 220 VDC	Making capacity: 130 W, $L/R < 40$ ms Breaking capacity: 25 W, $L/R < 40$ ms
Switch with gold-plated contacts ¹⁾	230 VAC	Max. 6.9 VA, $\cos \varphi = 0.9$
	24... 220 VDC	Max. 6.6 W, $L/R < 25$ ms

¹⁾ Switching higher loads destroys the gold plating.

Micro-switch arrangement (examples)



Depending on your order, the micro-switch arrangements can deviate from the following versions.

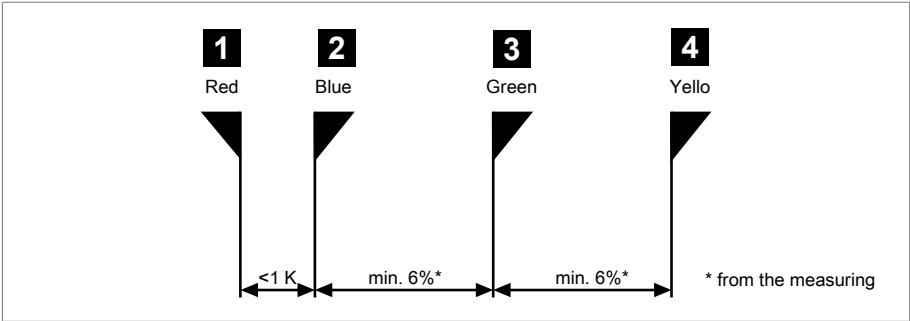

Figure 74: Switch arrangement 1+2

1 + 2

tight

$<1 K$

with standard model

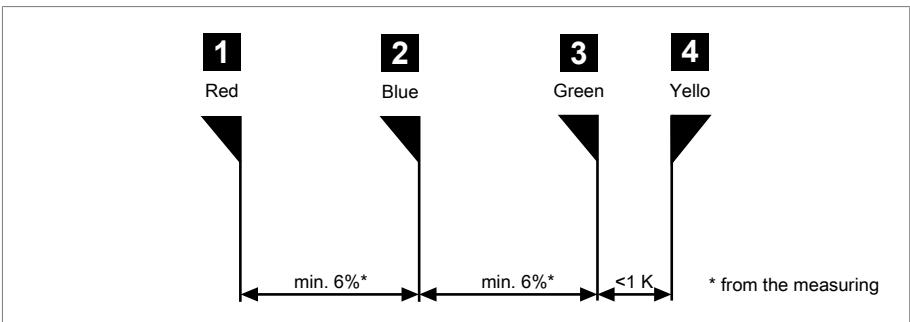

Figure 75: Switch arrangement 3+4

3 + 4

tight

$<1 K$

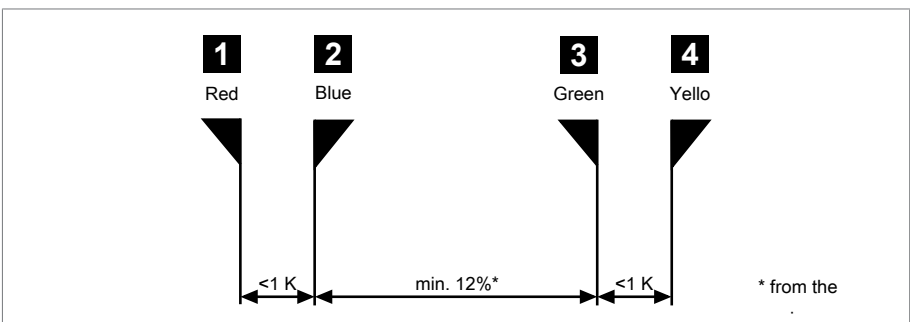

Figure 76: Switch arrangement 1+2 and 3+4

1 + 2 and 3 + 4

tight

$<1 K$

11 Technical data

11.4 Modbus RTU

Factory settings

Device version	Modbus address	Baud rate	Parity
MESSKO® COMPACT (RM) Oil temperature indicator MT-ST160SK/... MT-ST160SK/.../RM	21	19200	EVEN
MESSKO® COMPACT (RM) Winding temperature indicator MT-ST160W(R)/... MT-ST160W(R)/.../RM	22	19200	EVEN

Table 14: Modbus RTU factory settings

Input register

Function code "04" to read the information.



Validity of the measured value stored in the INPUT register addresses 1...3:

It can be seen via the DISC register address with address 4 (Boolean) whether the measured value is invalid (0) or valid (1). We recommend evaluating this register address alongside the measured value query.

Device status:

The INPUT register address 0 indicates the device status (0: the device self-diagnostic could not find any errors). We recommend querying the device status either parallel to the measured values or when needed (e.g. during troubleshooting, fault elimination).

For details, see Fault elimination.

Address	Data type	Designation
0	UINT16	Device status, see under status codes [► Section 9.5, Page 98]
1, 2	FLOAT32	Measured value (temperature in °C) with decimal places; Oil temperature or Winding temperature
3	SINT16	Measured value (temperature in °C) as an integer; Oil temperature or Winding temperature
4...16	-	Reserved for future use

Address	Data type	Designation
17	UINT16	Firmware version major
18	UINT16	Firmware version minor
19	UINT16	Firmware version patch

Table 15: Input register

With FLOAT parameters, the MSB (Most Significant Bit) is stored in the lower address and the LSB (Least Significant Bit) in the higher address.

Configuration via holding register



Each address must be unique in the BUS system. Therefore, for example, when using two identical devices (same default address!), configure them to different addresses before commissioning!

Use function code "03" to read the information and function code "06/16" to write the information.

Address	Data type	Designation	Setting option
0	UINT16	Modbus address	1...247 21 ¹⁾ (oil temperature indicator) 22 ¹⁾ (winding temperature indicator)
1	UINT16	Modbus baud rate	0: 4800 1: 9600 2: 19200 ¹⁾ 3: 38400 4: 57600 5: 115200
2	UINT16	Modbus parity	0: None 1: Even ¹⁾ 2: Odd
3	-	Reserved	-
4	-	4...20 mA analog output	0: Deactivated 1: Activated ¹⁾²⁾

11 Technical data

Address	Data type	Designation	Setting option
5...72	-	Reserved	-
73...79 ³⁾	STRING	Serial number	7-digit, 1 number per register in ASCII-format

Table 16: Holding register

¹⁾ Delivery condition/default settings

²⁾ We recommend deactivating the 4...20 mA analog output when it is not needed. This will prevent the pseudo-error "4...20 mA output defective". This will also reduce the power loss in the device and extend its service life.

³⁾ Cannot be overwritten by the user.

Validity of the measured value via DISC register

Use function code "02" to read the information from DISC register address 4.

Address	Data type	Designation
4	BOOL	Validity of the measured value (input register 1...3): 0: Invalid 1: Valid

12.1 Compact pointer thermometer dimensions

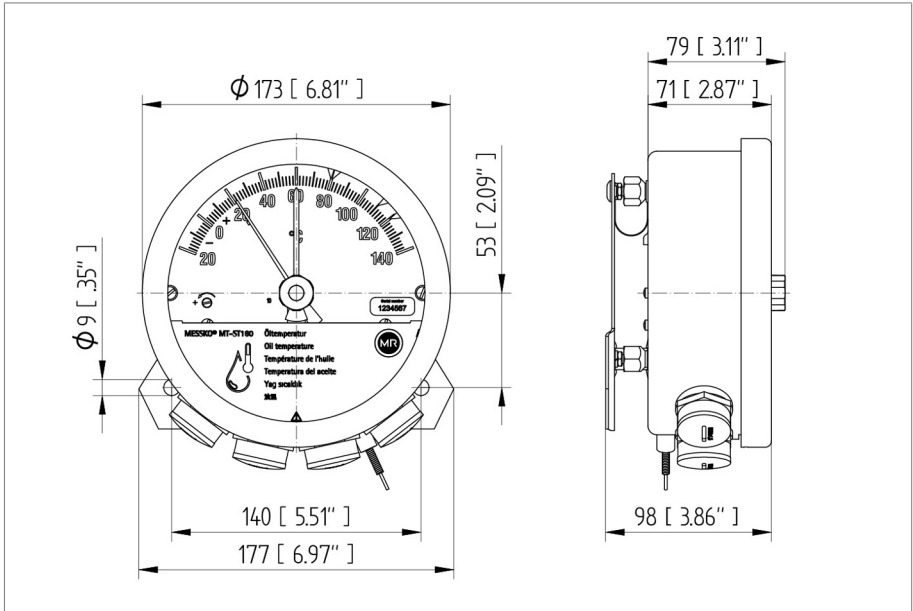

Figure 77: MESSKO® Compact

12 Appendix

12.2 Compact RM pointer thermometer dimensions

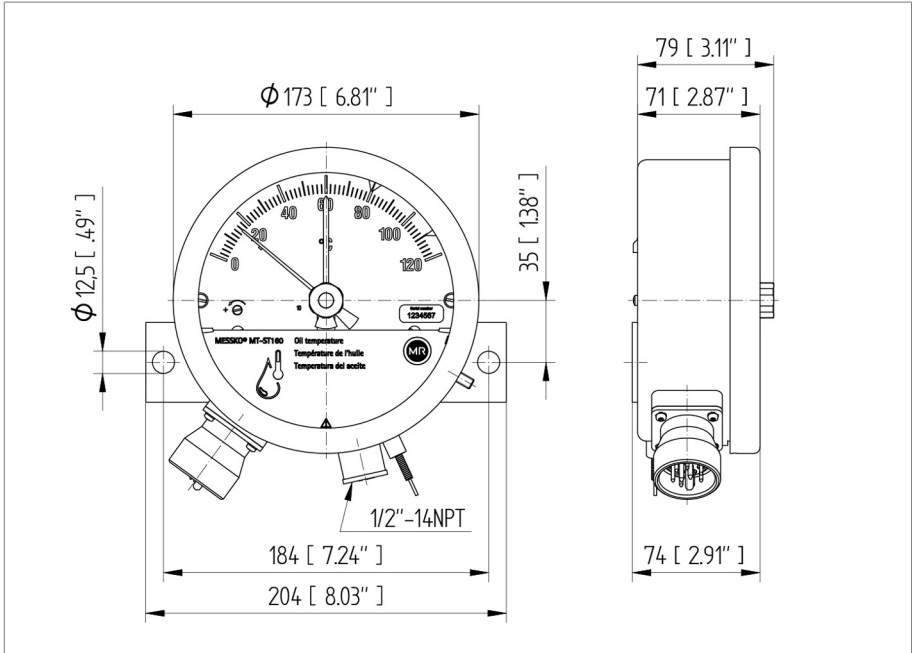

Figure 78: MESSKO® Compact RM

12.3 Temperature sensor

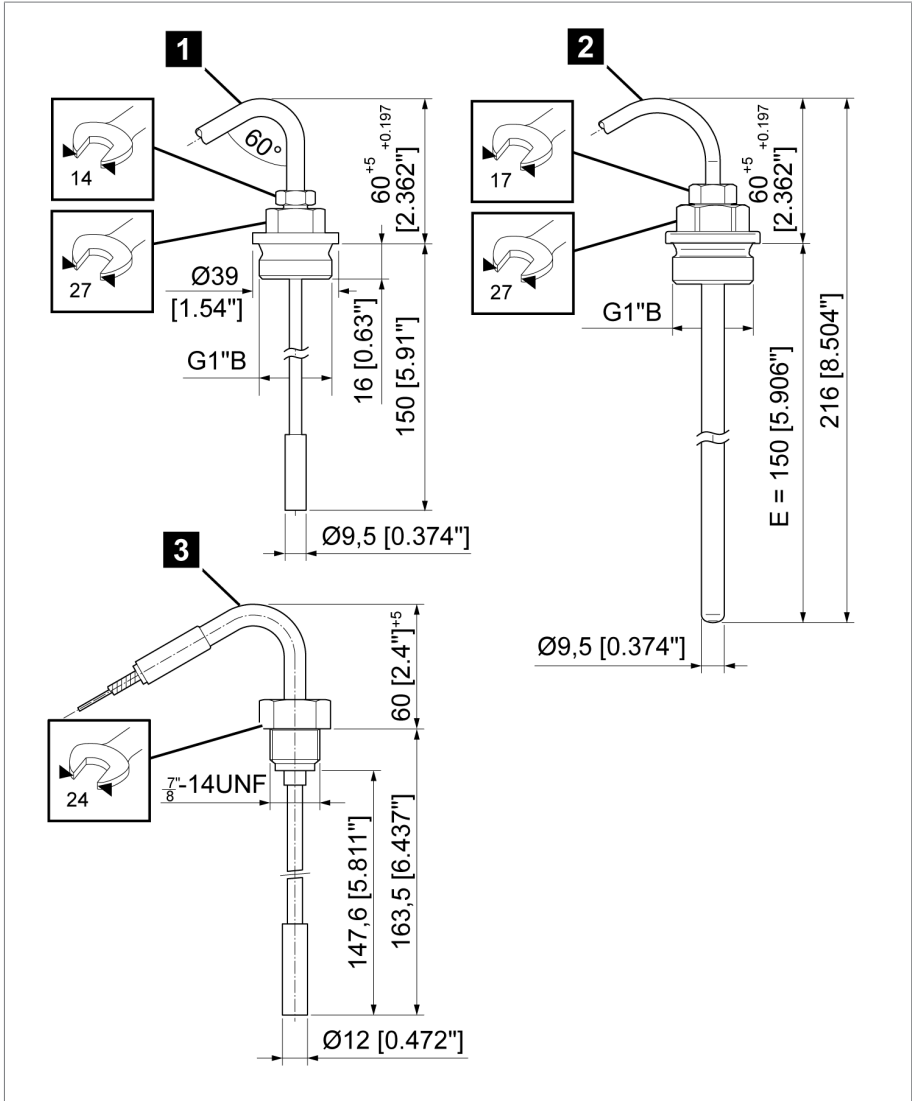

Figure 79: Temperature sensor

1 Standard variant (No. 7)

2 Offshore variant (No. 6 VA)

3 For Compact RM (No. 7 RM)

12 Appendix

12.4 Step protection

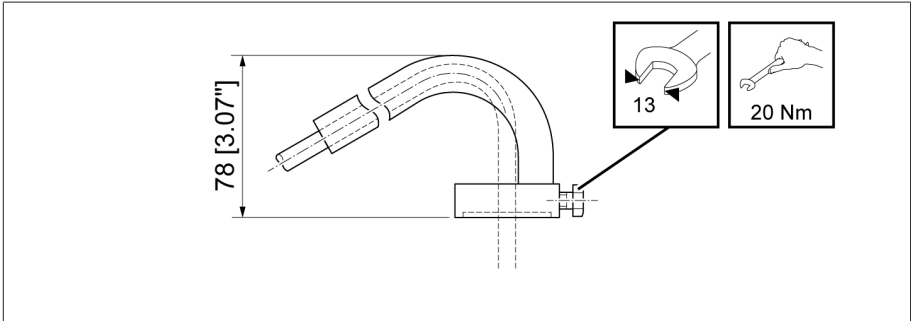

Figure 80: Step protection (only in combination with sensor No. 6 VA and sensor No. 7)

12.5 Vibration-damping plate/Mounting plate

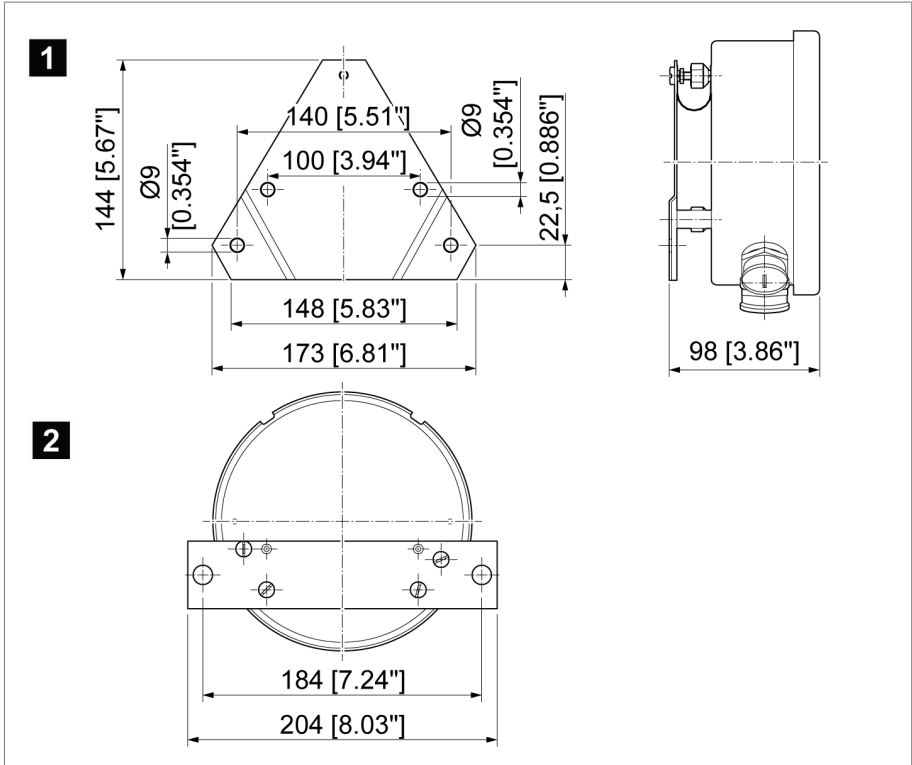

Figure 81: Dimensional drawing for vibration-damping plate and mounting plate

1 Vibration-damping plate (Compact standard)

2 Mounting plate (Compact RM)

12 Appendix

12.6 Cable gland dimensions

Standard cable gland

M25x1.5 nickel-plated brass

Clamping range 9...20 mm

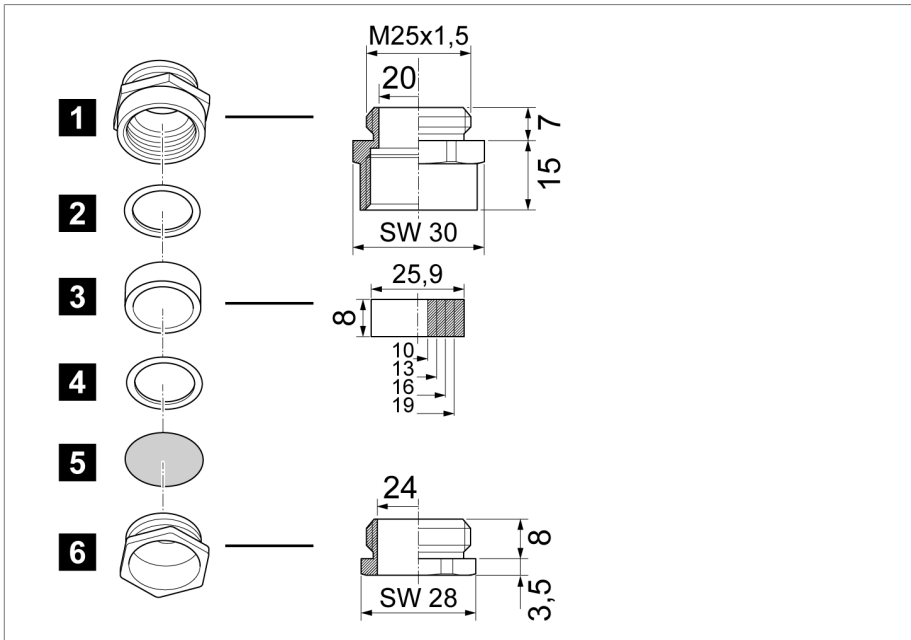

Figure 82: Standard cable gland

1 Gland base

2 Pressure ring

3 Universal sealing ring, NBR

4 Pressure ring

5 Dust protection disk

6 Pressure screw

WADI cable screw connection (water-tight; optional)

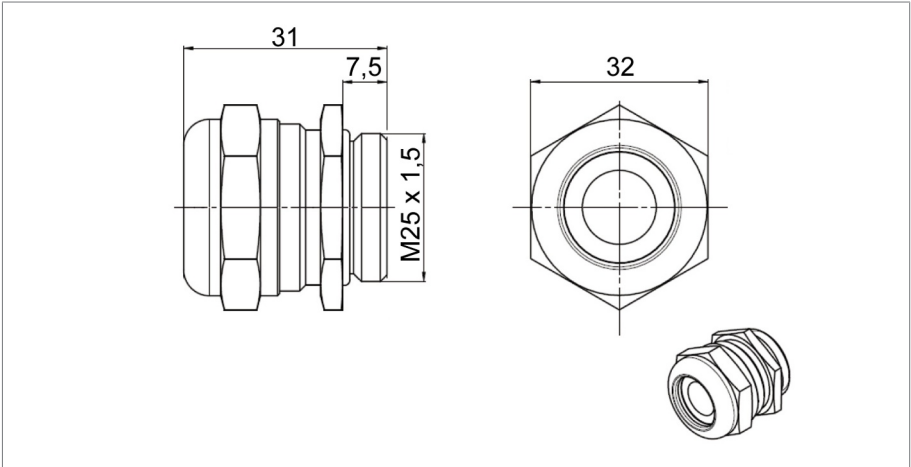

Figure 83: WADI cable screw connection; material: nickel-plated brass; clamping range 13...20 mm

Offshore cable screw connection (optional)

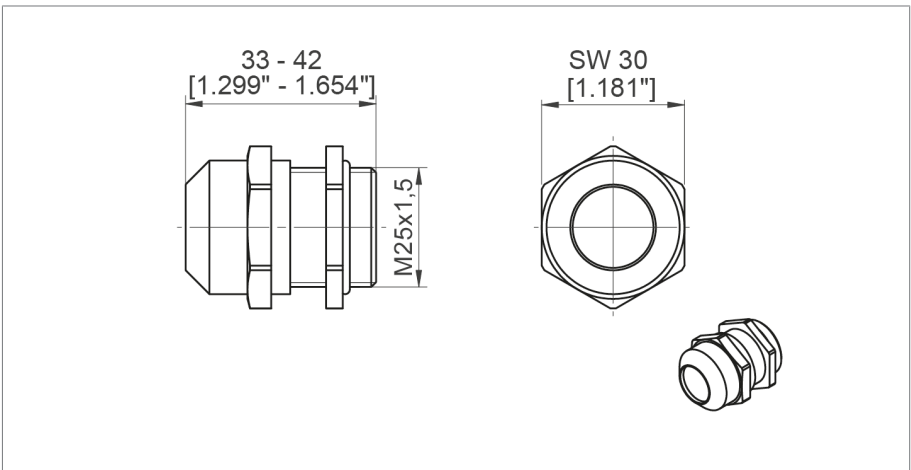

Figure 84: Offshore cable screw connection; material: stainless steel (V4A); clamping range 9...17 mm

12 Appendix

NPT adapters (optional)

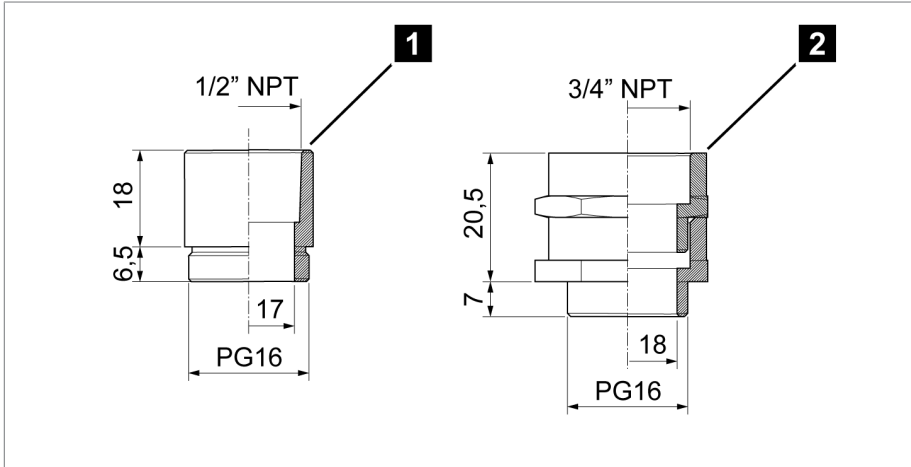

Figure 85: NPT adapters

1 1/2" NPT

2 3/4" NPT

EMC double cable gland (optional)

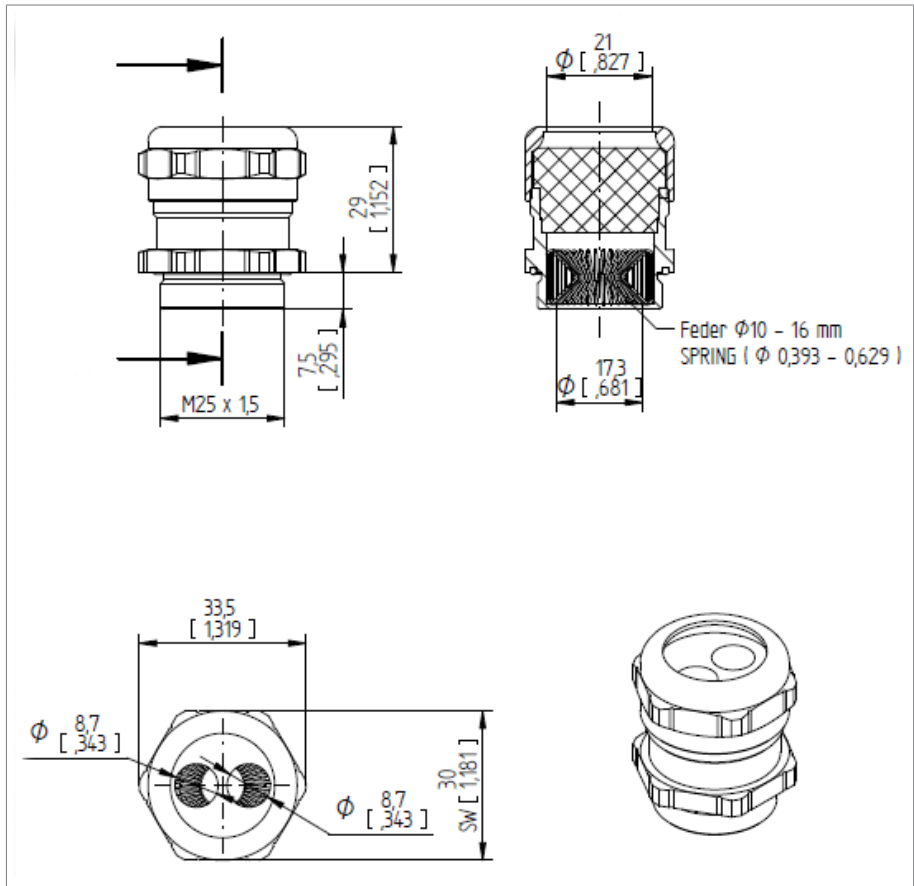

Figure 86: EMC double cable gland

Glossary

Ambient air temperature

Permissible temperature of the air in the surroundings of the equipment in operation on which the device is installed.

CT

EMC

Electromagnetic compatibility

Operating temperature

Permissible temperature in the immediate surroundings of the device during operation taking ambient influences, for example due to the equipment and installation location, into consideration.

SCADA

Storage temperature

Permissible temperature for storing the device in an unmounted state or in a mounted state so long as the device is not in operation.

Maschinenfabrik Reinhausen GmbH

Falkensteinstrasse 8
93059 Regensburg

☎ +49 (0)941 4090-0

✉ sales@reinhausen.com

www.reinhausen.com

5831400/02 EN - MESSKO® COMPACT -
F0389202 - 05/23 - Maschinenfabrik Reinhausen GmbH 2023

THE POWER BEHIND POWER.

