



Design/versions

This technical document contains detailed information about the technical properties of the product. If you would like to place an order, please use the MESSKO inquiry and order specification, which you can also find on our website <http://www.reinhausen.com> below the respective product.

The flow indicator consists of a display part and a transmitter part (flange with paddle). Depending on the cooling medium used, the display part is labeled with WATER or OIL (mineral insulating oil, alternative insulating fluids).

The micro-switches installed in the flow indicator are designed as changeover contacts, which you can electrically connect using either a terminal box or an ANSI plug / MIL plug.

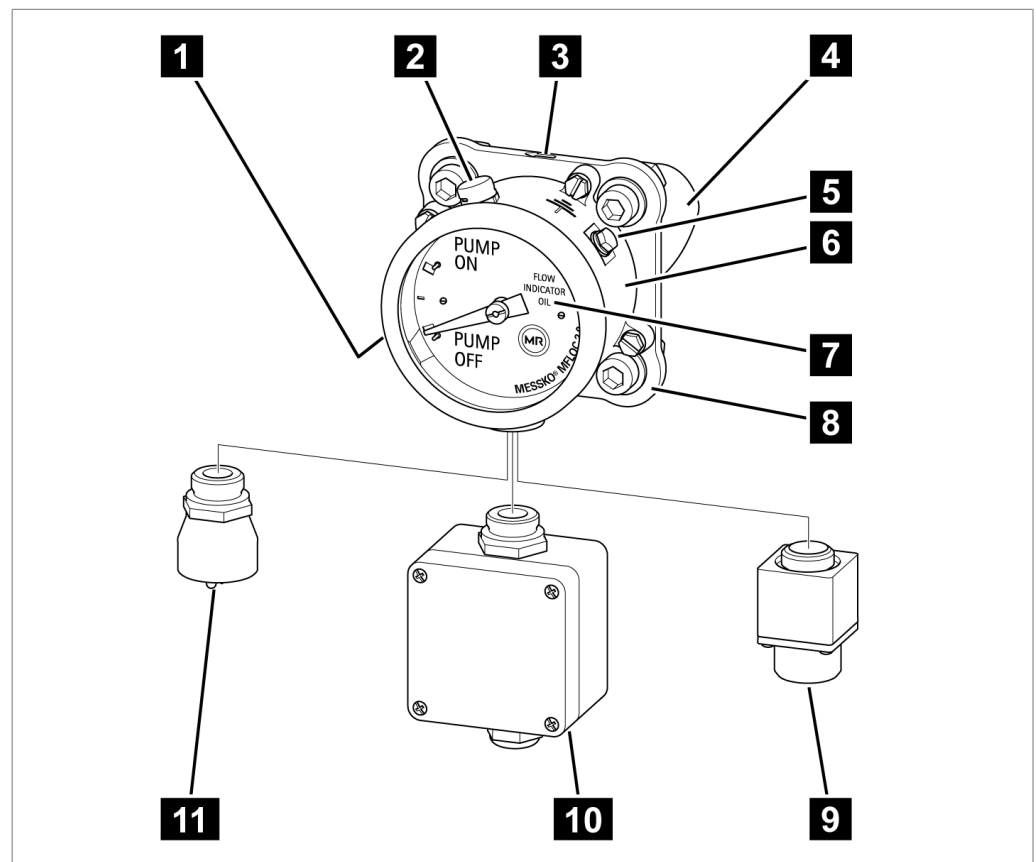
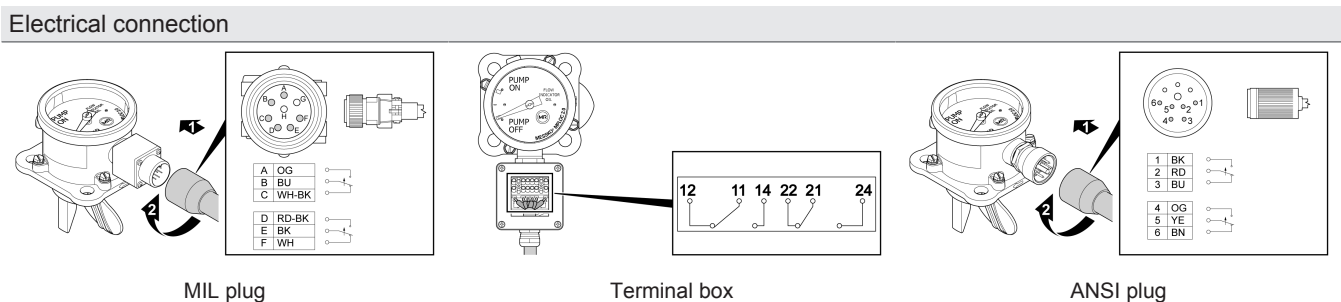

Figure 1: MESSKO® MFLOC 2.0

1 Nameplate	2 Pressure equalization element
3 Marking for mounting position	4 Paddle
5 Grounding screw	6 Display part
7 Type of cooling medium used	8 Transmitter part
9 MIL plug	10 Terminal box with M20x1.5 or 3/4" NPT cable screw connection
11 ANSI plug	

Technical data

Basic materials	
Housing / terminal box	Aluminum alloy, RAL 7033 or 7038, powder-coated in accordance with DIN EN ISO 12944 part 9, class C4H or CX
Mounting flange	Aluminum alloy
Paddle	Glass fiber-reinforced plastic / polyamide copolymer, 50% glass fiber
Indicator dial	Aluminum, matted, anodized Color: black text on white indicator dial or white text on black indicator dial or yellow text on black indicator dial
Viewing glass	Laminated safety glass with UV filter
Specifications	
Setup	Indoors and outdoors, tropic-proof
Ambient temperature	-40 °C...+80 °C
Temperature of cooling medium	-30 °C...+120 °C
Degree of protection	IP54 in accordance with DIN EN 60 529
Rated insulation voltage	2.5 kVAC / 1 min
Weight including terminal box	2 kg
Weight without terminal box	1.5 kg
Nominal diameter of the pipe, flange version	DN100 to DN300
Pressure-tightness	Tested up to 3 bar oil pressure, 75 °C
Max. flow speed	2.5 [m/s] / 98.43 [inch/s]
Min. flow speed	0.7 [m/s] / 27.56 [inch/s]
Pressure loss	< 0.1 bar
Minimum flow speed for the flow indicator to respond	See table "Minimum flow speed for the flow indicator to respond"
Noise development	No perceptible emission
Flange gasket	
Material	NBR for mineral insulating oil FPM (Viton) for alternative insulating fluids EPDM for water
Material hardness	75 shore
Micro-switches	
Number and type	Two changeover contacts, electrically isolated, fixed setting
Max. contact rating	10 A / 250 V AC or 4 A / 24 V DC for a resistive load, reduced for offshore version
Min. contact rating	0.5 mA / 5 V DC
Switching point	Centered between PUMP ON and PUMP OFF
Rated insulation voltage	2.5 kV AC, 1 min, contacts to housing
Terminal box	
Connection terminals	min. 0.15 mm ² / max. 2.5 mm ²
Cable screw connection	M20x1.5 for cable Ø 8...15 mm or ¾" NPT
ANSI plug / MIL plug	
Cable type	6 x AWG16, SOOW, 600 V





Minimum flow speed for the flow indicator to respond						
Nominal diameter DN	Piping interior diameter in accordance with DIN 2633		Minimum flow speed for the flow indicator to respond		Oil flow rate for the flow indicator to respond	
	[mm]	[inch]	[m/s]	[inch/s]	[l/min]	[gallons/min]
100	107.10	4.22	0.70	27.56	380.00	100.39
125	131.70	5.19	0.70	27.56	572.00	151.11
150	159.30	6.27	0.70	27.56	837.00	221.11
200	207.30	8.16	0.70	27.56	1418.00	347.60
250	260.40	10.25	0.70	27.56	2236.00	590.69
300	309.70	12.19	0.70	27.56	3163.00	835.58

Cooling medium

Water

Mineral insulating oil as per IEC 60296

Alternative insulating fluids

Offshore model

Paint of terminal box as per DIN EN ISO 12944 Part 9, Protection class CX

Unpainted parts made from stainless steel

© MASCHINENFABRIK REINHAUSEN GMBH 2018
 THE REPRODUCTION, DISTRIBUTION AND UTILIZATION OF THIS DOCUMENT AS WELL AS THE COMMUNICATION OF ITS CONTENTS TO OTHERS WITHOUT EXPRESS AUTHORIZATION IS
 PROHIBITED. OFFENDERS WILL BE HELD LIABLE FOR THE PAYMENT OF DAMAGES. ALL RIGHTS RESERVED IN THE EVENT OF THE GRANT OF A PATENT, UTILITY MODEL OR DESIGN.

DATE	NAME	DOCUMENT NO.
15.10.2018	SCHAEFERB	SED 6323873 000 00
15.10.2018	HUBERTHO	CHANGE NO. SCALE
16.10.2018	PRODASTSCHUK	1090240 1:1,5

DIMENSION
 IN mm
 EXCEPT AS
 NOTED



TRANSFORMER ACCESSORIES
 FLOW INDICATOR MFloC
 VERSION WITH MIL CONNECTOR

SERIAL NUMBER

MATERIAL NUMBER
 101205890E

SHEET
 1 / 1

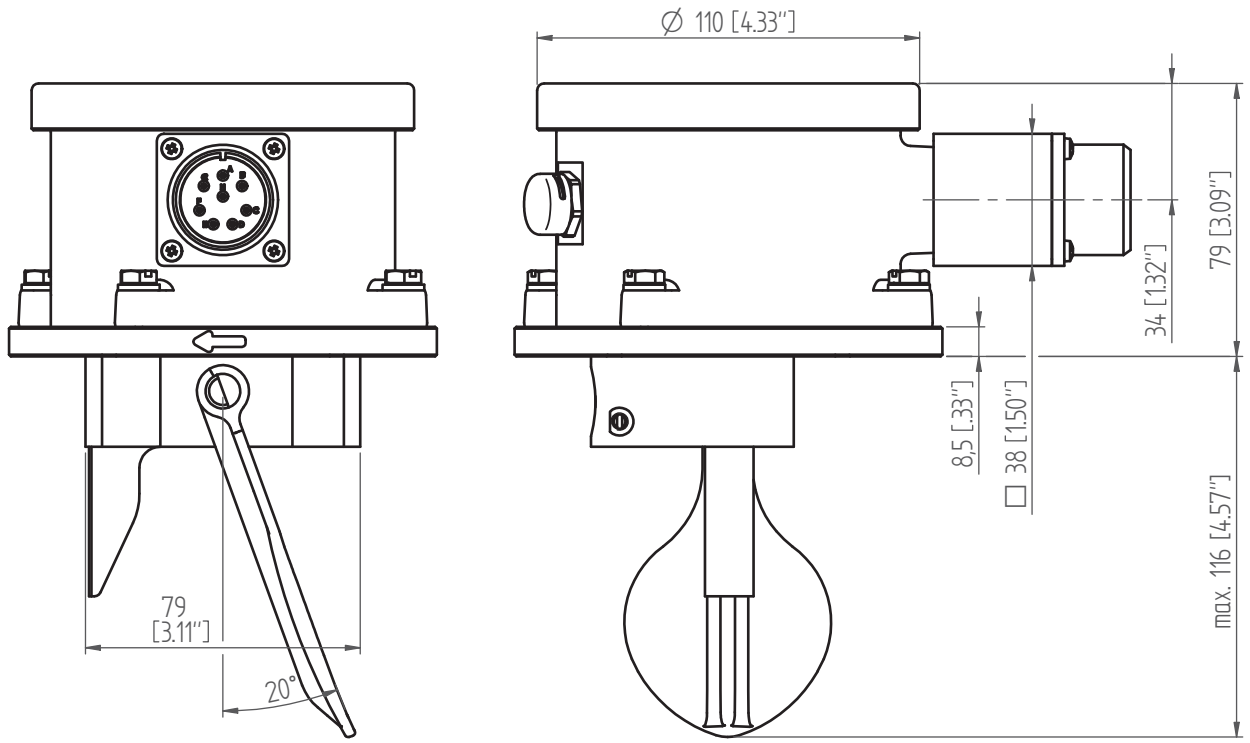
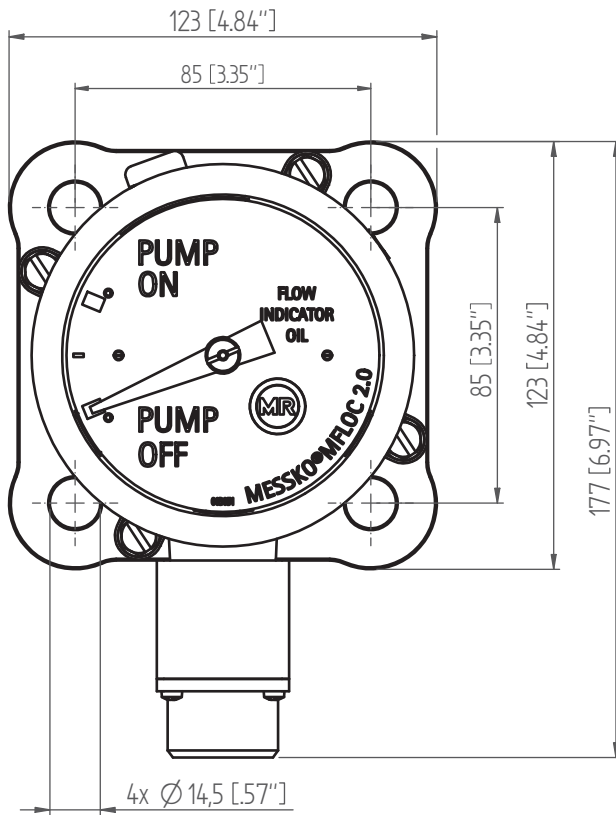

© MASCHINENFABRIK REINHAUSEN GMBH 2018
 THE REPRODUCTION, DISTRIBUTION AND UTILIZATION OF THIS DOCUMENT AS WELL AS THE COMMUNICATION OF ITS CONTENTS TO OTHERS WITHOUT EXPRESS AUTHORIZATION IS PROHIBITED. OFFENDERS WILL BE HELD LIABLE FOR THE PAYMENT OF DAMAGES. ALL RIGHTS RESERVED IN THE EVENT OF THE GRANT OF A PATENT, UTILITY MODEL OR DESIGN.

DATE	NAME	DOCUMENT NO.
14.01.2019	SCHAEFERB	SED 6323955 000 01
CHKD. 14.01.2019	HUBERTHO	CHANGE NO.
SCALE	1:1,5	1091766
STAND. 15.01.2019	KLEYN	

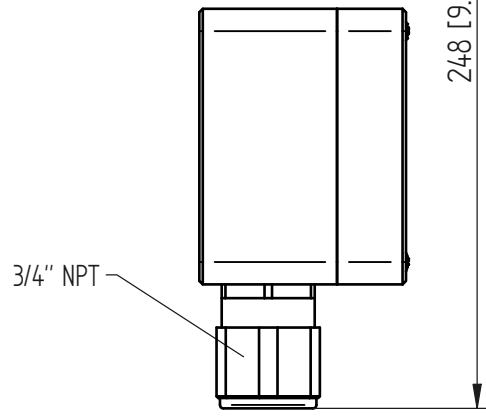
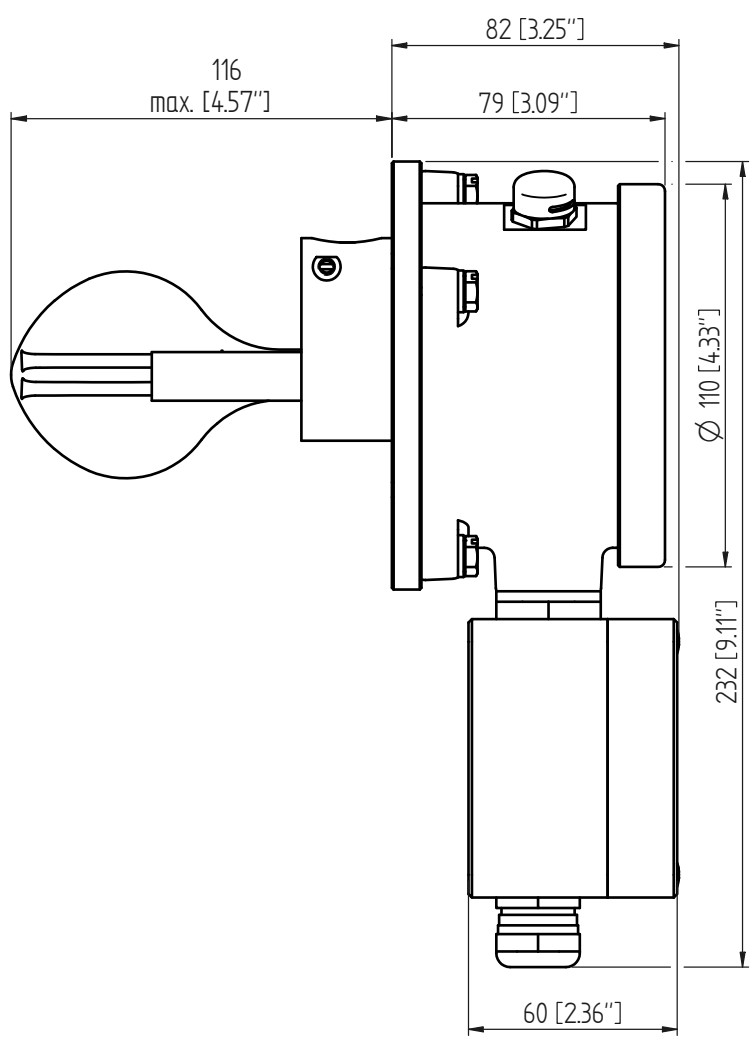
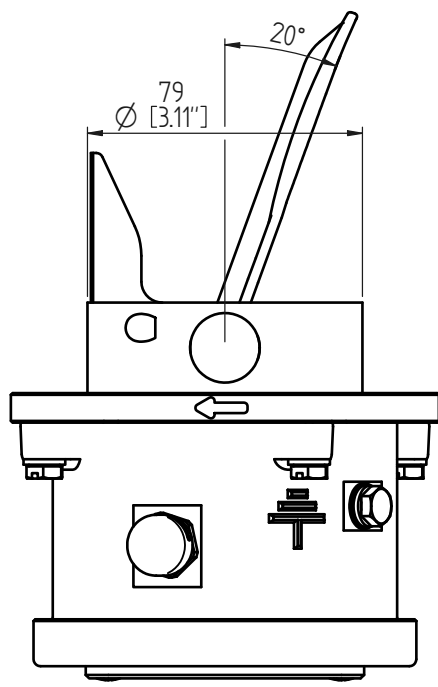
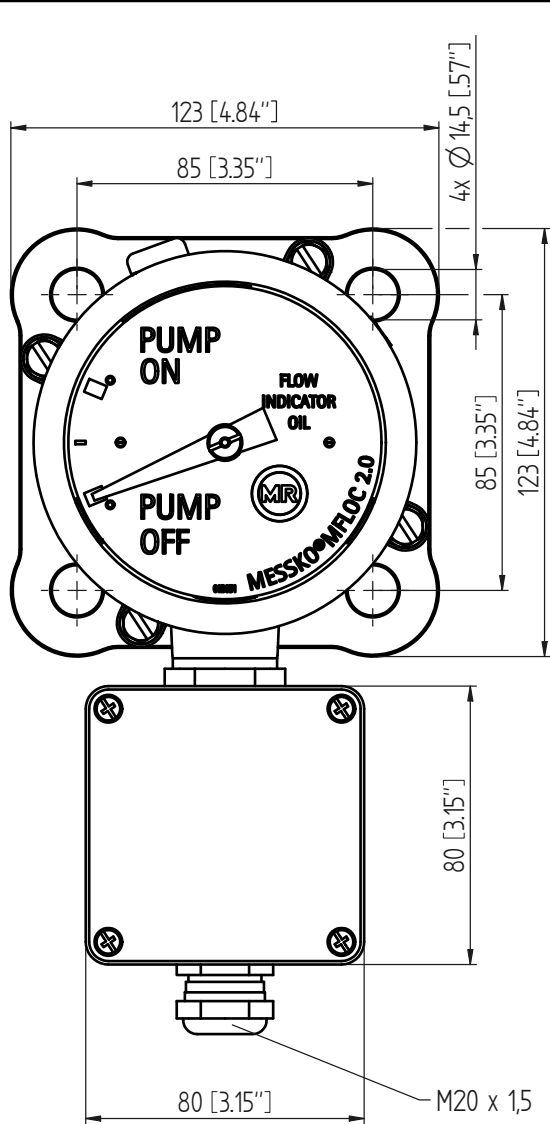

DIMENSION
 IN mm
 EXCEPT AS
 NOTED



TRANSFORMER ACCESSORIES
 FLOW INDICATOR MFloC
 VERSION WITH TERMINAL BOX

SERIAL NUMBER	
MATERIAL NUMBER	SHEET
101205870E	1 / 1

© MASCHINENFABRIK REINHAUSEN GMBH 2018
 THE REPRODUCTION, DISTRIBUTION AND UTILIZATION OF THIS DOCUMENT AS WELL AS THE COMMUNICATION OF ITS CONTENTS TO OTHERS WITHOUT EXPRESS AUTHORIZATION IS
 PROHIBITED. OFFENDERS WILL BE HELD LIABLE FOR THE PAYMENT OF DAMAGES. ALL RIGHTS RESERVED IN THE EVENT OF THE GRANT OF A PATENT, UTILITY MODEL OR DESIGN.

DATE	NAME	DOCUMENT NO.
DfTR. 15.10.2018	SCHAEFERB	SED 6323915 000 00
CHKD. 15.10.2018	HUBERTHO	CHANGE NO. SCALE
STAND. 16.10.2018	PRODASTSCHUK	1090240 1:1,5

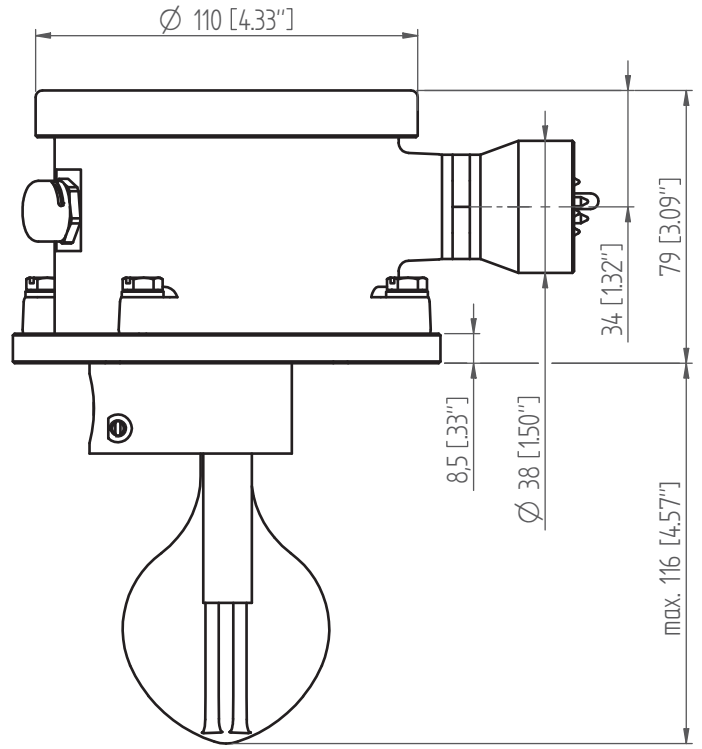
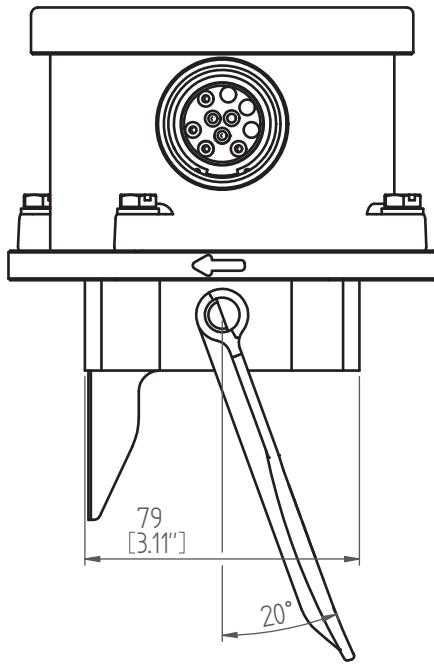
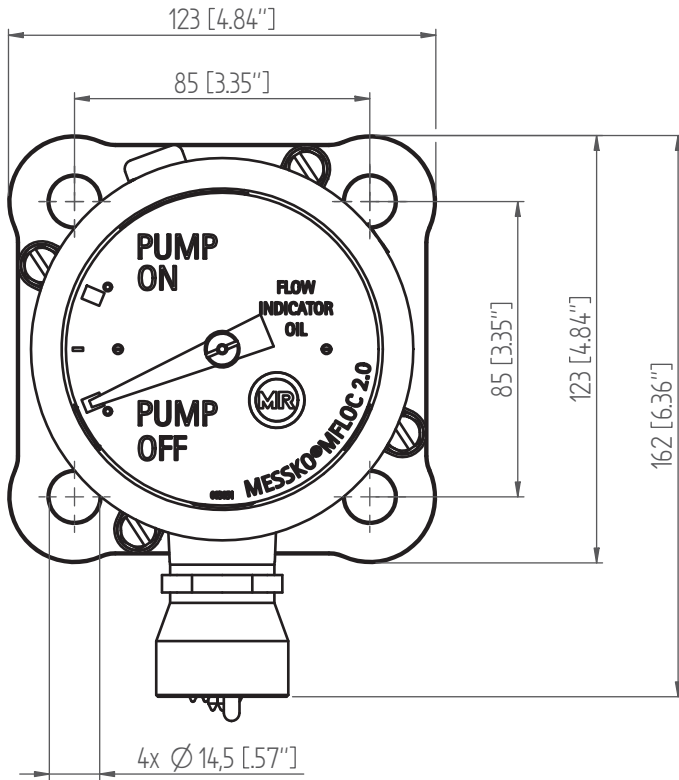

DIMENSION
 IN mm
 EXCEPT AS
 NOTED



TRANSFORMER ACCESSORIES
 FLOW INDICATOR MFLoC
 VERSION WITH ANSI CONNECTOR

SERIAL NUMBER

MATERIAL NUMBER
 101205880E

SHEET
 1 / 1

Messko GmbH

Gewerbegebiet An den Drei Hasen
Messko-Platz 1
61440 Oberursel, Germany

☎ +49 (0)6171 6398 0

📠 +49 (0)6171 6398 98

✉ messko-info@reinhausen.com

www.reinhausen.com/messko

6667895/00 EN - MESSKO® MFLOC 2.0 -
F0375400 - 01/19 - Messko GmbH 2019

THE POWER BEHIND POWER.

